



1	Warranty	5	6	Pitching the motorhome	39
2	Introduction	7	6.1	Handbrake	39
2.1	General	8	6.2	Entrance step	39
2.2	Environmental tips	8	6.3	Ramps	39
3	Safety	11	6.4	Supports	39
3.1	Fire prevention	11	6.4.1	General instructions	39
3.1.1	Avoidance of fire risks	11	6.4.2	Steady legs	40
3.1.2	Fire-fighting	11	6.5	240 V connection	40
3.1.3	In case of fire	11	6.6	Refrigerator	40
3.2	General	12	7	Living	41
3.3	Road safety	12	7.1	Doors	41
3.4	Towing	14	7.1.1	Driver's door, conversion door, outside	41
3.5	Gas system	14	7.1.2	Conversion door, inside	42
3.5.1	General instructions	14	7.1.3	Driver's door, inside (model I)	42
3.5.2	Gas bottles	15	7.1.4	Insect screen on the conversion door, extendable	43
3.6	Electrical system	16	7.2	External flaps	43
3.7	Water system	16	7.2.1	Flap lock, elliptical-shaped	44
4	Before the journey	17	7.3	Ventilation	44
4.1	Initial start-up	17	7.4	Windows	45
4.2	Registration	17	7.4.1	Sliding window without lock	45
4.3	Payload	18	7.4.2	Hinged window with automatic hinges	46
4.3.1	Terms	18	7.4.3	Roman shade for windscreen and side panes	47
4.3.2	Calculating the payload	21	7.4.4	Blind and insect screen	48
4.3.3	Loading the vehicle correctly	22	7.4.5	Sunroof with rotary hinges	49
4.3.4	Rear garage/rear storage space	23	7.4.6	Roman shade and insect screen	50
4.3.5	Bike rack	24	7.5	Skylights	51
4.4	Entrance step	25	7.5.1	Skylight with snap latch	52
4.5	Roman shade for windscreen and side panes	26	7.5.2	Heki skylight (mini and midi)	53
4.6	PVC-floor covering	26	7.6	Tables	55
4.7	Television	27	7.6.1	Suspension table with fold-out leg	55
4.8	Branch block (model I)	27	7.6.2	Lift-off table	56
4.9	Bonnet (model I)	28	7.7	Lamps	57
4.10	Filling in windscreen washer fluid (model I)	28	7.7.1	LED lamp (model I)	57
4.11	Checking engine oil level (model I) ..	29	7.8	TV unit	57
4.12	Snow chains	29	7.9	Beds	59
4.13	Road safety	30	7.9.1	Overcab bed	59
5	During the journey	33	7.9.2	Pull-down bed	60
5.1	Driving the motorhome	33	7.9.3	Bunk bed	61
5.2	Driving speed	34	7.9.4	Fixed bed (gas-pressure springs)	62
5.3	Brakes	34	7.9.5	Lying surface of rear single beds	63
5.4	Seat belts	35	7.10	Converting seating groups for sleeping	63
5.4.1	Fastening the seat belt correctly	35	7.10.1	Central seating group	63
5.5	Driver's seat and front passenger's seat	36	7.10.2	Front bench seat with divan	64
5.6	Headrests	36	7.10.3	Front bench seat with lengthwise seat	65
5.7	Seating arrangement	36	7.10.4	Front bench seat (guest bed)	66
5.8	Tablet holder	37			
5.9	Electrical window winder	37			
5.10	Electrically adjustable sexternal mirrors	38			
5.11	Filling up with diesel	38			



8	Gas system	67	10.4	Refrigerator.....	103
8.1	General.....	67	10.4.1	Refrigerator ventilation grill.....	104
8.2	Gas bottles.....	69	10.4.2	Operation (Thetford).....	104
8.3	Gas consumption.....	70	10.4.3	Refrigerator door locking mechanism.....	106
8.4	Changing gas bottles.....	70			
8.5	Gas isolator taps.....	71			
9	Electrical system	73	11	Sanitary fittings	107
9.1	General safety instructions.....	73	11.1	Water supply, general.....	107
9.2	Terms.....	73	11.2	Water tank.....	108
9.3	12 V power supply.....	74	11.2.1	Drinking water filler neck with cap.....	108
9.3.1	Living area battery.....	75	11.2.2	Filling the water system.....	108
9.3.2	Charging batteries via a 240 V power supply.....	76	11.2.3	Topping up the water.....	109
9.3.3	Charging batteries via the vehicle engine.....	76	11.2.4	Reducing the water quantity for mobile operation.....	110
9.3.4	Charging the starter battery.....	76	11.2.5	Draining water.....	110
9.4	Transformer/rectifier (EBL 119).....	78	11.2.6	Emptying the water system.....	111
9.4.1	Battery cut-off switch.....	79	11.2.7	Position of the safety/drainage valve.....	112
9.4.2	Battery selector switch.....	79	11.3	Waste water tank.....	112
9.4.3	Battery monitor.....	80	11.4	Toilet compartment.....	113
9.4.4	Charging the battery.....	80	11.5	Vario toilet compartment.....	114
9.5	Panel (LT 100).....	81	11.6	Toilet.....	115
9.5.1	12 V main switch.....	81	11.6.1	Thetford toilet.....	115
9.5.2	LED array for battery voltage.....	82	11.6.2	Emptying the sewage tank.....	117
9.5.3	LED array for tank fill level.....	83	11.6.3	Winter operation.....	118
9.6	240 V power supply.....	84	11.6.4	Temporary lay-up.....	118
9.6.1	240 V connection (CEE socket outlet).....	84			
9.6.2	Connecting the 240 V power supply.....	84	12	Care	119
9.7	Fuses.....	86	12.1	External care.....	119
9.7.1	12 V fuses.....	86	12.1.1	General.....	119
9.7.2	240 V fuse.....	88	12.1.2	Washing with a high-pressure cleaner.....	119
10	Appliances	89	12.1.3	Washing the vehicle.....	120
10.1	General.....	89	12.1.4	Windows of acrylic glass.....	120
10.2	Heater / production of hot water.....	90	12.1.5	Underbody.....	120
10.2.1	Models with waste gas vent on the right-hand side of the vehicle.....	90	12.1.6	Entrance step.....	121
10.2.2	Safety switch.....	91	12.2	Interior care.....	121
10.2.3	To heat properly.....	91	12.3	Water system.....	122
10.2.4	Heater and production of hot water (Truma Combi).....	92	12.3.1	Cleaning the water tank.....	122
10.2.5	Hot-air heater and boiler with CP plus digital operating unit.....	93	12.3.2	Cleaning the water pipes.....	122
10.2.6	Safety/drainage valve.....	97	12.3.3	Disinfecting the water system.....	123
10.2.7	Wall flue.....	98	12.3.4	Waste water tank.....	123
10.2.8	Electrical floor warming unit.....	99	12.4	Extractor hood (recirculating).....	124
10.3	Cooker.....	100	12.5	Winter care.....	125
10.3.1	Gas cooker.....	100	12.5.1	Preparations.....	125
10.3.2	Gas oven with grill (Thetford Duplex).....	101	12.5.2	Winter operation.....	125
10.3.3	Extractor hood (recirculating).....	103	12.5.3	At the end of the winter season.....	125
			12.6	Lay-up.....	126
			12.6.1	Temporary lay-up.....	126
			12.6.2	Winter lay-up.....	127
			12.6.3	Starting up the vehicle after a temporary lay-up or after lay-up over winter.....	128



13	Maintenance	129	16	Helpful notes	147
13.1	Inspection work	129	16.1	Traffic rules in foreign countries	147
13.2	Maintenance work	129	16.2	Help on Europe's roads	147
13.3	Replacing bulbs, external	129	16.3	Gas supply in European countries	148
13.3.1	Front lights	130	16.4	Toll regulations in European countries	148
13.3.2	Rear lights	131	16.5	Tips on staying overnight safely during travel	149
13.4	Replacing bulbs, internal	132	16.6	Tips for winter campers	149
13.4.1	LED lamps	132	16.7	Travel checklists	150
13.5	Spare parts	133			
13.6	Vehicle identification plate	134			
13.7	Warning and information stickers	134			
14	Wheels and tyres	135			
14.1	General	135			
14.2	Tyre selection	136			
14.3	Tyre specifications	137			
14.4	Handling of tyres	137			
14.5	Tightening torque	137			
14.6	Tyre pressure	137			
15	Troubleshooting	139			
15.1	Chapter overview	139			
15.2	Braking system	139			
15.3	Electrical system	139			
15.4	Gas system	141			
15.5	Cooker	142			
15.6	Extractor hood	142			
15.7	Heater/boiler	142			
15.8	Refrigerator	144			
15.9	Water supply	145			
15.10	Body	146			

Contents





Warranty certificate

Vehicle data
Model:
Car manufacturer/type of engine:
Serial number:
Delivery date:
Initial registration:
Purchased from company:
Expiry of the warranty period:
Key number:
Chassis number:
Customer address:
Surname, Christian name:
Street, house number:
Postal code, town:
Dealer's stamp and signature

We reserve the right to alter the construction, equipment and the scope of delivery. Special equipment is also listed that is not included in the standard scope of delivery. The descriptions and illustrations in this brochure do not relate to a particular version. For all details, only the respective equipment list is valid.





Please read this instruction manual completely before using the vehicle for the first time!

Always keep this instruction manual in the vehicle. Also inform all other users of the safety regulations.



- ▶ The non-observance of this symbol can lead to personal injury.



- ▷ The non-observance of this symbol can lead to damage being caused to, or inside the vehicle.



- ▷ This symbol indicates recommendations or special aspects.



- ▷ This symbol indicates actions which lead to environmental awareness.

With your motorhome you will receive a file with the following vehicle manuals and documents:

- Operating and installation instructions of various appliances
- Complete set of documents from the chassis manufacturer
- Test certificate for the gas system in accordance with German regulations

This instruction manual contains sections which describe model-specific equipment or special equipment. These sections are not specially marked. It may be that your vehicle has not been fitted with this special equipment. In some cases, the actual equipment of your vehicle may therefore be different from that shown in some illustrations and descriptions.

However, your vehicle may be fitted with other special equipment not described in this instruction manual.

Special equipment is described when an explanation is required.

Adhere to the instruction manuals which are separately enclosed.



- ▷ The details "right", "left", "front" and "rear" always refer to the vehicle in direction of travel.
- ▷ All dimensions and weight details are "approximate".
- ▷ The metric specifications are binding for physical dimensions.

Should the vehicle be subjected to damage due to a failure to follow the instructions in this instruction manual, then the warranty claim is deemed invalid.

Our vehicles are subjected to continuous development. Please understand that we reserve the right to alter the form, equipment and technology. Therefore, no claims can be made against the manufacturer as a result of the contents of this instruction manual. The equipment which was known and included at the time of going to press is described.

The reprinting, translation and copying, including extracts is not permitted without prior written authorisation from the manufacturer.



2.1 General

The motorhome is a product of Capron GmbH.

The vehicle is constructed in accordance with the latest technology and the recognised safety regulations. Nevertheless, personal injury may result and the vehicle may be damaged if the safety instructions in this instruction manual are not followed.

Before using the vehicle for the first time, equip it with the legally prescribed equipment (e.g. first aid kit, warning vest, hazard warning triangle etc.). Observe the relevant equipment regulations when travelling abroad.

Only use the vehicle in a technically impeccable condition. Follow the instructions in the instruction manual.

Malfunctions which impair the safety of persons or the vehicle should be immediately remedied by qualified personnel. To avoid further damages, observe the duty to avert, minimise or mitigate loss for the user during faults.

Have the vehicle's braking and gas systems inspected and repaired by an authorised specialist workshop only.

Alterations to the body are only to be carried out with the authorisation of the manufacturer.

The vehicle is designed for the exclusive transport of persons. Luggage and accessories may only be transported up to the maximum permissible gross weight.

Observe the test and inspection periods stipulated by the manufacturer.

2.2 Environmental tips



- ▷ Be considerate of the environment.
- ▷ Remember that: All kinds of waste water and household waste are not to be disposed of in drains or in the open countryside.
- ▷ On board, collect waste water only in the waste water tank or – if necessary – in other containers designed for that purpose.
- ▷ Only empty the waste water tank and sewage tank at disposal stations, camping sites or caravan sites especially provided for this purpose. When stopping in towns and communities, observe the instructions at caravan sites or ask where there are disposal stations.
- ▷ Empty waste water tank as often as possible, even when it is not completely full (hygiene).
If possible, flush out waste water tank and, if necessary, drainage pipe with fresh water every time it is emptied.
- ▷ Never allow the sewage tank to become too full. Empty the sewage tank frequently, at the latest as soon as the filling level display lights up.
- ▷ Separate household waste according to glass, tin cans, plastic and wet waste also when on a journey. Enquire at the town or community authority about disposal points. Household waste is not to be disposed of in waste paper baskets which are situated at car parks.
- ▷ Empty waste bins as often as possible into the containers provided for this purpose. This helps to avoid unpleasant smells and an accumulation of rubbish on board.



- ▷ When parked, do not allow the engine to run more than necessary. When running idle, a cold engine releases more contaminants than usual. The running temperature of the engine is achieved more quickly whilst the vehicle is in motion.
- ▷ Use an environmentally-friendly WC chemical agent for the WC which can also be biologically degraded and only use small doses.
- ▷ When staying in towns and communities for long periods, search for parking areas which are specially reserved for motorhomes. Enquire at the town or community authority about parking spaces.
- ▷ Always leave the parking places in a clean condition.





Chapter overview

This chapter contains important safety instructions. The safety instructions are for the protection of persons and property.

The instructions address the following topics:

- fire prevention and what to do in case of fire
- general care of the vehicle
- road safety of the vehicle
- towing
- gas system of the vehicle
- electrical system of the vehicle
- water system of the vehicle

3.1 Fire prevention

3.1.1 Avoidance of fire risks



- ▶ Never leave children in the vehicle unattended.
- ▶ Keep flammable materials clear of heating and cooking appliances.
- ▶ Never use portable heating or cooking appliances.
- ▶ Only authorised qualified personnel may make changes to the electrical system, gas system or appliances.

3.1.2 Fire-fighting



- ▶ Always carry a dry powder fire extinguisher in the vehicle. The fire extinguisher must be approved, tested and close at hand.
- ▶ The fire extinguisher is not included in the scope of delivery.
- ▶ Have the fire extinguisher tested at regular intervals by authorised qualified personnel. Observe the date of testing.
- ▶ Always keep a fire blanket near the cooker.

3.1.3 In case of fire



- ▶ Evacuate all passengers.
- ▶ Cut off the electrical power supply and disconnect from the mains.
- ▶ Close regulator tap on the gas bottle.
- ▶ Sound the alarm and call the fire brigade.
- ▶ Fight the fire if this is possible without risk.



- ▷ Acquaint yourself with the position and operation of the emergency exits.
- ▷ Keep escape routes clear.
- ▷ Observe the fire extinguisher instructions for use.

All windows and doors which meet the following requirements are considered as emergency exits:

- Open to the outside or can be shifted in horizontal direction
- Opening angle at least 70°
- Minimum diameter of clearance = 450 mm
- Maximum distance from the vehicle floor = 950 mm



3.2 General



- ▶ The oxygen in the vehicle interior is used up by breathing and the use of gas operated appliances. That is why the used air must be replaced permanently. For this purpose, forced ventilation options (e.g. skylights with forced ventilation) are fitted to the vehicle. Never cover or block forced ventilations from the inside or outside with objects such as e.g. a winter mat. Keep forced ventilations clear of snow and leaves. There is a danger of suffocation due to increased CO₂ levels.
- ▶ Do not use storage spaces or rear garages as places for people or animals to stay or sleep in. These spaces are not forced-air ventilated. There is a danger of suffocation due to oxygen deprivation or exhaust from the heater.
- ▶ Observe the headroom of the doors.



- ▷ As far as the fitted appliances (heater, cooker, refrigerator, etc.) and the base vehicle (engine, brakes, etc.) are concerned, the instruction manuals are authoritative. It is imperative that they be observed.
- ▷ Fitting accessories or special equipment can alter the dimensions, weight and road behaviour of the vehicle. Some of the parts must be entered in the vehicle papers.
- ▷ Only use wheel rims and tyres which are approved for the vehicle. Information concerning the size of the approved wheel rims and tyres is included in the vehicle documents or can be obtained from authorised dealers and service centres.
- ▷ Firmly apply the handbrake when parking the vehicle.



- ▷ When leaving the vehicle, it is imperative that all doors, external flaps and windows are closed.
- ▷ Always carry the legally prescribed equipment (e.g. first aid kit, warning vest, hazard warning triangle etc.) with you. The regulations of the host country apply when travelling abroad.
- ▷ The vehicle may only be driven by drivers who hold a driving licence which is valid for the respective vehicle class.
- ▷ When selling the vehicle, hand over all instruction manuals for the vehicle and the fitted appliances.

3.3 Road safety



- ▶ Before commencing the journey, carry out a functional check of indicating and lighting equipment, the steering and the brakes.
- ▶ If the vehicle has been stationary for a long period (approx. 10 months) have the braking and gas systems checked by an authorised specialist workshop.
- ▶ Before commencing the journey and after short interruptions of the journey, ensure that the entrance step is completely retracted.
- ▶ Before commencing the journey, secure the pull-down bed.
- ▶ Before commencing the journey, rotate all swivel seats in the direction of travel and lock in position. During the journey, the swivel seats must remain locked in place in the direction of travel.
- ▶ Before commencing the journey, store the television securely.



- ▶ During the journey, persons are only to sit on the permitted seats (see chapter 5). The authorised number of seats is stipulated in the vehicle documents.
- ▶ Seat belts must be worn by all passengers.
- ▶ Fasten your seat belts before the beginning of the journey and keep them fastened during the journey.
- ▶ It is not permitted to stay in the alcove during the journey.
- ▶ Always secure children with the children safety equipment prescribed for the respective height and weight.
- ▶ Only attach the child restraint system to seats that are specified for this purpose. Only forward-facing child restraint systems are permitted.
- ▶ The base vehicle is a commercial vehicle (small truck). Adjust your driving technique accordingly.
- ▶ In case of underpasses, tunnels or similar obstacles, note the total height of the vehicle (including the roof load).
- ▶ In winter, the roof must be free of snow and ice before commencing the journey.
- ▶ Check tyre pressure before a journey or every 2 weeks. Wrong tyre pressure causes excessive wear and can lead to damage or even to tyre burst. You can lose control of the vehicle (see section 14.6).
- ▶ Do not operate the heater at petrol stations. Danger of explosion!
- ▶ Do not operate the heater in closed spaces. Danger of suffocation!



- ▷ Before commencing the journey, distribute the payload evenly within the vehicle (see chapter 4).
- ▷ When loading the vehicle and when taking a rest from driving, in order to load luggage or food, for example, observe the maximum permissible gross weight and axle loads (refer to vehicle documents).
- ▷ Before commencing the journey, ensure that all cupboard doors, the toilet compartment door and all drawers and flaps are secure. Engage the refrigerator door securing device.
- ▷ Before commencing the journey, close windows and skylights.
- ▷ Before commencing the journey, close all external flaps and lock them.
- ▷ Before commencing the journey, remove external supports.
- ▷ Before commencing the journey, put the antenna in park position.
- ▷ During the initial journey and each time after changing a wheel, re-tighten the wheel bolts/wheel nuts after 50 km (30 miles). Subsequently inspect them at regular intervals in order to ensure that they are firmly seated. See chapter 14 for tightening torque.
- ▷ Tyres may not be older than 6 years as the material becomes brittle over time (see chapter 14).
- ▷ When using snow chains, the tyres, wheel suspension and steering are subjected to an additional load. When using snow chains, drive slowly (maximum speed 50 km/h) and only on streets which are completely covered with snow. Otherwise the vehicle could be damaged.



3.4 Towing



- ▶ Care is to be taken when connecting and detaching a trailer. Risk of accident and injury!
- ▶ No persons are to be between the towing vehicle and the trailer during positioning for connecting and detaching.

3.5 Gas system

3.5.1 General instructions



- ▶ The operator of the gas system is responsible for the performance of recurring inspections and for complying with the maintenance intervals.
- ▶ Before commencing the journey, when leaving the vehicle or when gas equipment is not in use, close all gas isolator taps and the main isolator tap on the gas bottle.
- ▶ All gas-operated devices (heater, cooker, oven, grill, refrigerator - depending on the equipment) must be switched off for refuelling, on ferries or in the garage. Danger of explosion!
- ▶ Do not use gas-operated devices in closed spaces (e.g. garages). Danger of poisoning and suffocation!
- ▶ Only have the gas system maintained, repaired or altered by an authorised specialist workshop.
- ▶ Have the gas system checked by an authorised specialist workshop according to the national regulations before commissioning. This also applies for not registered vehicles. For modifications to the gas system have the gas system immediately checked by an authorised specialist workshop.
- ▶ The gas pressure regulator, the gas tubes, and the exhaust gas pipes must also be inspected. The gas pressure regulator and the gas tubes must be replaced observing the nationally defined deadlines (the latest after 10 years). The vehicle owner is responsible for seeing that this is carried out.
- ▶ In case of a defect of the gas system (gas odour, high gas consumption) there is danger of explosion! Close regulator tap on the gas bottle immediately. Open doors and windows and ventilate well.
- ▶ If the gas system is defective: Do not smoke; do not ignite any open flames, and do not operate electric switches (light switches etc.). Check the tightness of gas-conducting parts and lines with leakage search spray. Do not check with an open flame.
- ▶ Only the stipulated devices may be connected to internal connections. Do not operate any device outside the vehicle if it is connected to an internal connector.
- ▶ Before using the cooker make sure that there is sufficient ventilation. Open a window or the skylight.
- ▶ Do not use gas-operated cooking and baking facilities for heating purposes.
- ▶ If there are several gas devices, each gas device must have its own gas isolator tap. If individual gas devices are not in use, close the respective gas isolator tap.



- ▶ Ignition safety valves must close within 1 minute after the gas flame has extinguished. A clicking sound is audible. Check function from time to time.
- ▶ The built-in gas devices are exclusively meant for use with propane or butane gas or a mixture of both. The gas pressure regulator as well as all built-in gas devices are designed for a gas pressure of 30 mbar.
- ▶ Propane gas is capable of gasification up to $-42\text{ }^{\circ}\text{C}$, whereas butane gas gasifies at $0\text{ }^{\circ}\text{C}$. Below these temperatures no gas pressure is available. Butane gas is unsuitable for use in winter.
- ▶ Due to its function and construction, the gas bottle compartment is a space which is open to the exterior. Never cover or block up the standard forced ventilations. Otherwise gas that is emitted can not be diverted to the outside.
- ▶ The gas bottle compartment must not be used as storage space.
- ▶ Secure the gas bottle compartment against unauthorised access. To do this, lock the compartment.
- ▶ The regulator tap on the gas bottle must be accessible.
- ▶ Only connect gas-operated devices (e.g. gas grill) which have been designed for a gas pressure of 30 mbar.
- ▶ The exhaust gas pipe must be fitted tightly to the heating system and to the vent and must be sealed. The exhaust gas pipe must not show any evidence of damage.
- ▶ Exhaust fumes must be able to escape into the atmosphere unhindered and fresh air must be able to enter unhindered. For this reason, keep the exhaust pipe and intake openings clean and unobstructed (e.g. free from snow and ice). For this reason, no snow walls or aprons may lie against the vehicle.

3.5.2 Gas bottles



- ▶ Handle full or emptied gas bottles outside the vehicle only with closed regulator tap and attached protective cap.
- ▶ Gas bottles are only to be transported within the designated gas bottle compartment.
- ▶ Place the gas bottles in vertical position in the gas bottle compartment.
- ▶ Fasten the gas bottles so that they are unable to turn or tilt.
- ▶ Connect the gas tube to the gas bottle without tension.
- ▶ If the gas bottles are not connected to the gas tube, always place the protective cap on top.
- ▶ Close the regulator tap on the gas bottle before the gas pressure regulator or gas tube are removed from the gas bottle.
- ▶ Depending on the connection, unscrew the gas tube from the gas bottle and screw it on the gas bottle again by hand or using a suitable special spanner. The screw connection on the gas bottle generally has a left-hand thread. **Do not** tighten too firmly.
- ▶ Only use special gas pressure regulators with a safety valve designed for vehicle use. Other gas pressure regulators are not permitted and cannot meet the demanding requirements.



- ▶ Use the gas pressure regulator defroster if the temperature falls below 5 °C.
- ▶ Use only 11 kg or 5 kg gas bottles. Camping gas bottles with built-in check valve (blue bottle with max. 2.5 or 3 kg content) are can be used in exceptional cases with a safety valve.
- ▶ Use the shortest possible tube lengths (150 cm max.) for external gas bottles.
- ▶ Never block the floor ventilation openings below the gas bottles.

3.6 Electrical system



- ▶ Only allow qualified personnel to work on the electrical system.
- ▶ Prior to carrying out work on the electrical system, switch off all devices and lights, disconnect the battery and disconnect the vehicle from the mains.
- ▶ Only use original fuses with the stipulated values.
- ▶ Only replace defective fuses when the cause of the defect is known and has been remedied.
- ▶ Never bridge or repair fuses.

3.7 Water system



- ▶ Water left standing in the water tank or in the water pipes becomes undrinkable after a short period. Therefore, before each use of the vehicle, thoroughly clean the water pipes and the water tank. After each use of the vehicle completely empty the water tank and the water pipes.
- ▶ In the case of lay-ups lasting more than a week disinfect the water system before using the vehicle (see chapter 12).



- ▷ If the vehicle is not used for several days or if it is not heated when there is a risk of frost, empty the entire water system. Make sure that the 12 V power supply on the panel is switched off. Otherwise, the water pump will overheat and may get damaged. Leave the water taps on in central position. Leave the safety/drainage valve (if there is one) and all drain cocks open. Frost damage to appliances, frost damage to the vehicle and deposits in water-carrying components can be avoided in this way.



Chapter overview

This chapter contains important information which has to be noted before commencing your journey or carrying out any tasks before the journey.

The instructions address the following topics:

- initial start-up
- registration
- calculating the payload
- correct loading of the vehicle and bike rack
- towing
- retracting and extending the entrance step
- PVC-floor covering
- storing the television
- using the branch block
- opening the bonnet
- filling in windscreen washer fluid
- checking the engine oil level
- using snow chains

At the end of the chapter there is a checklist which once again summarises the most important points.

4.1 Initial start-up



- ▷ During the initial journey and each time after changing a wheel, re-tighten the wheel bolts/wheel nuts after 50 km (30 miles). Subsequently inspect them at regular intervals in order to ensure that they are firmly seated. See chapter 14 for tightening torque.

The motorhome is supplied with a set of keys, consisting of keys for the base vehicle and keys for the body.

Always deposit a replacement key outside the vehicle. Make a note of the key number. Our authorised dealers and workshops can offer assistance in case of loss.

4.2 Registration

Your motorhome is a vehicle which must be registered. Observe national regulations on registration.

Please remember that certain countries require a separate national code sticker in addition to the EU plate.



4.3 Payload



- ▶ Overloading the vehicle and wrong tyre pressure can cause tyres to burst. You can lose control of the vehicle (see section 14.6).
- ▶ The maximum permissible gross weight and the weight including special equipment fitted at the factory (actual weight) is shown in the vehicle documents, but not the weight of the loaded vehicle (see section 4.3.1). For your own safety, we recommend that you have your loaded vehicle (with all passengers, luggage and personal objects) weighed on a public weighbridge before you set out on your journey.
- ▶ Adapt the speed to the payload. The stopping distance is increased if the payload is high.



- ▷ Do not exceed the maximum permissible gross weight (permissible total weight) stated in the vehicle documents and the maximum axle loads as a result of the payload.
- ▷ Built-in accessories and special equipment reduce the payload.
- ▷ Adhere to the axle load stated in the vehicle documents.

On loading, make sure that the payload's centre of gravity is as low as possible (directly above the floor of the vehicle). Otherwise this may affect the driving characteristics of the vehicle.

Maximum permitted payloads

Description	Load (kg)
Bike rack Quadruple	60
Motorcycle rack	100
Rear garage and rear storage space	150 ¹⁾
Overcab bed	200
Rear bed	200
Bunk beds	100
Pull-down bed	250
Cupboard beneath pull-down bed, left and right (each)	5

¹⁾ If the vehicle is fitted with a caravan coupling, the permitted load is 250 kg.

4.3.1 Terms



- ▷ Technically speaking, the term "mass" has now replaced the term "weight". However, "weight" is still the term more frequent in common use. For better understanding, "mass" is therefore only used in the following sections for fixed formulations.

Maximum permissible gross weight in a laden condition

The maximum permissible gross weight in a laden condition is the weight that a vehicle may never exceed.

The maximum permissible gross weight in a laden condition consists of the **actual weight** and the **payload**.

In the vehicle documents, the manufacturer has specified the maximum permissible gross weight in a laden condition.

Actual weight

The actual weight consists of the mass in ready-to-drive condition and the weight of the special equipment fitted at the factory.



Mass in ready-to-drive condition

The mass in ready-to-drive condition is the weight of the ready-to-drive standard vehicle (excluding special equipment fitted at the factory).

The mass in ready-to-drive condition is made up as follows:

- Unladen weight (mass of the empty vehicle) with factory-installed standard equipment (excluding special equipment fitted at the factory)
- Driver's weight
- Basic equipment weight

Unladen weight includes lubricants such as oils and coolants which have been filled, the on-board tool set, the spare wheel or the tyre repair kit and a fuel tank which has been filled up to 90 %.

75 kg are calculated for the weight of the driver, regardless of how much the driver really weighs.

Basic equipment includes all equipment and fluids required for safe and proper vehicle use. The weight of the basic equipment includes:

- A full fresh water system
- A gas bottle filled up to 90 %
- A full heating system
- The power cables for the 240 V power supply
- A full toilet flushing system
- The installation kit for an auxiliary battery if an auxiliary battery can be used

The waste water and sewage tanks are empty.

Example for calculating the basic equipment

Water tank with 100 l (for weight reasons, filling quantity can be reduced by opening an overflow tap at the factory)	100 kg
Gas bottle (10 kg _{Gas} + 5.5 kg _{Aluminium bottle})	+ 15.5 kg
Boiler with 10 l	+ 10 kg
240 V power cable	+ 4 kg
Installation kit for auxiliary battery	+ 6 kg
Total	= 135.5 kg

The weight in ready-to-drive condition and the actual weight are shown by the manufacturer in the vehicle documents.

Payload

The payload is made up as follows:

- Conventional load
- Additional equipment
- Personal equipment



▷ The vehicle's payload can be increased by reducing the actual weight. To do this, it is allowed for example to empty the fluid containers or to remove the gas bottles.

You will find explanations on the individual components of the payload in the following text.



Conventional load The conventional load is the weight specified by the manufacturer for the passengers.

Conventional load means: 75 kg are calculated for every seat specified by the manufacturer, regardless of how much the passengers actually weigh. The driver's seat is already included as part of the mass in ready-to-drive condition and must **not** be calculated as part of the conventional load.

In the vehicle documents, the manufacturer specifies the number of seats.

Additional equipment Additional equipment includes accessories and special equipment. Examples of additional equipment include:

- Caravan coupling
- Roof rail
- Awning
- Bike or motorcycle rack
- Satellite unit

Information about the weights of the various special equipment devices can be obtained from the manufacturer.

Personal equipment Personal equipment includes all items in the vehicle that are not included in the conventional load or in the additional equipment. For example, personal equipment can include the following:

- Foodstuffs
- Crockery
- Clothes
- Bedding
- Toys
- Books
- Toiletries
- Small electrical appliances (e.g. coffee machine)

No matter where kept, personal equipment also includes:

- Animals
- Bikes
- Sports equipment

For the personal equipment, according to the applicable regulations, the manufacturer must use a minimum weight that is determined according to the following formula:

Formula Minimum weight M (kg) = $10 \times N + 10 \times L$

Explanation N = maximum number of people including the driver, as stated by the manufacturer
 L = total length of the vehicle in metres



4.3.2 Calculating the payload



- ▶ The payload calculation at the factory is partly based on all-inclusive weights. For safety reasons, the maximum permissible gross weight in a laden condition must not be exceeded.
- ▶ The maximum permissible gross weight and the weight including special equipment fitted at the factory (actual weight) is shown in the vehicle documents, but not the weight of the loaded vehicle (see section 4.3.1). For your own safety, we recommend that you have your loaded vehicle (with all passengers, luggage and personal objects) weighed on a public weighbridge before you set out on your journey.

The payload (see section 4.3.1) is the difference in weight between

- the maximum permissible gross weight in a laden condition and
- the actual weight.

Example for calculating the payload

	Mass in kg to be calculated	Calculation
Maximum permissible gross weight according to vehicle documents	3500	
Actual weight including basic equipment according to vehicle documents	- 3070	
This results in a permissible payload of	430	
Conventional load e.g.: 3 persons each weighing 75 kg	- 225	
Additional equipment	- 40	
For the personal equipment this results in	= 165	

The calculation of the payload from the difference between the maximum permissible gross weight in laden condition and the actual weight specified by the manufacturer is however only a theoretical value.

Only if the vehicle is weighed with full tanks (fuel and water), full gas bottles and complete additional equipment on a public weighbridge, can the actual payload be determined.

To do this, proceed as follows:

- First only drive the vehicle on to the weighbridge with the front wheels and have it weighed.
- Then drive the vehicle on to the weighbridge with the back wheels and have it weighed.

The individual values give the current axle loads. These are important for the correct loading of the vehicle (see section 4.3.3). The sum of these values is the current weight of the vehicle.



The actual payload is the difference between the maximum permissible gross weight in laden condition and the weighed vehicle weight.

This can be used to determine the weight that remains for the personal equipment:

- Determine the weight of the passengers and subtract it from the value for the actual payload.

The result is the weight that is permitted for the actual load of the personal equipment.

4.3.3 Loading the vehicle correctly



- ▶ For safety reasons, never exceed the maximum permissible gross weight in a laden condition.
- ▶ Distribute the load evenly on the left and right sides of the vehicle.
- ▶ Distribute the load evenly on both axles. In doing so, observe the axle loads specified in the vehicle documents. Observe the permissible load-carrying capacity of the tyres (see chapter 14).
- ▶ Heavy loads behind the rear axle can reduce the load on the front axle due to the leverage effect ($\frac{A}{R}$). This applies especially to long rear extensions, if a motorbike is transported on the rear carrier or if there is a heavy load in the rear storage space. The release of the front axle negatively affects the driving quality, especially for front-driven vehicles.
- ▶ Store all objects in such a way that they cannot slip.
- ▶ Store heavy objects (awning, tin cans, etc.) close to the axles. Low-lying storage spaces whose doors do not open in the direction of travel are particularly suited for storing heavy objects.
- ▶ Stack light objects (laundry) in the roof storage cabinets.
- ▶ Load the bike rack with bicycles only (max. four units).

Large storage spaces, such as the rear garage, also have room for heavy objects (e.g. motorcycle). This might mean that the axle load on the rear axle is exceeded.

However, the individual axles may not be overloaded under any circumstances. That is why it is important, at which distance to the axles the load is stored.

To distribute the load correctly, you will need a scale, a tape measure, a calculator and some time.

Two simple formulas are needed to calculate the effect of the weight of the load on the axles:

Formulas $A \times G : R = \text{weight on the rear axle}$

Weight on the rear axle – $G = \text{weight on the front axle}$

Explanation

A = distance between storage space and front axle in cm

G = weight of the load in the storage space in kg

R = wheelbase of the vehicle (distance between axles) in cm



- ▶ Measure the external distances horizontally from the centre of the front wheel to the centre of the storage space or to the centre of the back wheel.



Calculating axle loads:

- Multiply the distance between storage space and front axle (A) with the weight of the load in the storage space (G) and divide the result by the wheelbase (R). The result is the weight of the load in the storage space on the rear axle. Make a note of this weight and of the storage space.
- In a second step, subtract the weight in the storage space (G) from the weight calculated beforehand. If the result is a **positive** value (example 1), this means that the load on the front axle is **reduced** by this value. If the result is a **negative** value (example 2), this means that the load on the front axle is **increased**. Make a note of this value, too.
- Calculate all storage spaces of the vehicle in the same way.
- In a last step, add all weights calculated for the rear axle to the rear axle load and add (or subtract) all weights calculated for the front axle to (from) the front axle load.
How to determine rear axle load and front axle load is described in section 4.3.2.

If the calculated value exceeds the permissible axle load, the load must be distributed in a different way.

If the load on the front axle is too low, the grip of the tyres on the road is reduced (traction), as is the vehicle's steerability. This applies in particular to vehicles with front-wheel drive. In this case, the load must be redistributed, too.

Example calculation

		Example 1	Example 2
Distance to the front axle	A	(A1) 450 (cm)	(A2) 250 (cm)
Weight in the storage space	G	x 100 (kg)	x 50 (kg)
Wheelbase of the vehicle	R	÷ 325 (cm)	÷ 325 (cm)
Load on the rear axle (add to the axle load)		138.5 (kg)	38.5 (kg)
Weight in the storage space		- 100 (kg)	- 50 (kg)
Load relief to the front axle (subtract from the axle load)		38.5 (kg)	
Load on the front axle (add to the axle load)			-11.5 (kg)

4.3.4 Rear garage/rear storage space



- ▶ Observe the permissible axle loads and maximum permissible gross weight when loading the rear garage/the rear storage space.
- ▶ The maximum permitted load of the rear garage/the rear storage space is 150 kg. If the vehicle is fitted with a caravan coupling, the permitted load is 250 kg. Do not exceed the permissible rear axle load.
- ▶ Observe: If the rear garage or (depending on the model) the rear storage space is **loaded** to its maximum capacity, this will **reduce the load** on the front axle due to the levering action. The driving quality is impaired.



- ▷ Distribute the load evenly. Excessive spot loads can lead to damages of the floor covering.



4.3.5 Bike rack



- ▶ Observe the permissible axle loads and maximum permissible gross weight when loading the bike rack.
- ▶ Bicycles may not jut out beyond the maximum width of the vehicle. Adjust the attachments for the bikes accordingly.
- ▶ Load the bike rack with bicycles only.
- ▶ Do not transport more than the permitted number of bicycles for the bike rack used.
- ▶ Check the secure attachment of the bicycles on the bike rack after the first 10 km and then at each break in the journey.



- ▷ The identification plate and rear lights must not be covered.
- ▷ Driving with a folded out bike rack without bicycles is not permitted.
- ▷ Before every journey, check:
 - Is the bike rack without bicycles folded in correctly?
 - Are the bicycles securely fastened to the bike rack using the bike rack belts?

Loading the bike rack with bicycles

When loading the bike rack, observe the centre of gravity. The centre of gravity of the bicycles must be as close as possible to the rear wall of the vehicle. The bike rack should always be loaded from the inside to the outside.

Loading the bike rack correctly:

- Depending on the model, fold the bike rack down or pull it out.
- Place the heaviest bicycle directly against the rear wall.
- Place the lightest bicycles in the centre or on the outside of the bike rack.
- Secure the front and rear wheels of each bicycle with the retaining straps on the bike rack.
- In addition, fasten the outermost bicycle depending on the model of the bike rack on the retaining clip or the retaining bracket and to the spacer respectively.

If the bike rack is only loaded with **one** bicycle, position the bicycle as closely as possible to the rear wall.



4.4 Entrance step



- ▶ Before commencing the journey and after short interruptions of the journey, ensure that the entrance step is completely retracted.
- ▶ Do not stand in the direct range of the entrance step while it is being retracted or extended.
- ▶ Do not step on the entrance step until it has extended completely. There is a risk of injury.
- ▶ Do not under any circumstances raise or lower persons or loads with the entrance step.



- ▷ Do not grease or lubricate the pivot bearing and joints of the entrance step (see chapter 12).



- ▷ The button to operate the entrance step is located on the inside of the vehicle in the area of the conversion door.
- ▷ If the entrance step has not been properly retracted and locked into place, a warning tone is heard when the ignition is switched on.

In part, the vehicles are not equipped with an electrical entrance step but with a low coupé entry that is comfortable to step on (model I).

Depending on the model, the vehicles have a one- or two-stage electrically extendable entrance step.

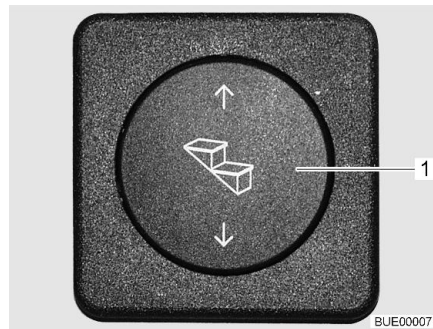


Fig. 1 Operating switch entrance step

Before stepping on the entrance step, fully extend it.

- Extending:**
- Press the rocker switch (Fig. 1,1) down until the entrance step has extended completely.
- Retracting:**
- Press the rocker switch (Fig. 1,1) up until the entrance step has retracted completely.



Emergency operation If the electric drive of the entrance step fails, follow the directions below to manually retract the entrance step:

- Pull out the securing splint from the connection to the engine.
- Release the rectangular connection to the engine using a suitable object (e.g. a screwdriver).
- Push in the entrance step by hand and secure it using a suitable device (e.g. a string).
- Contact customer service.

4.5 Roman shade for windscreen and side panes

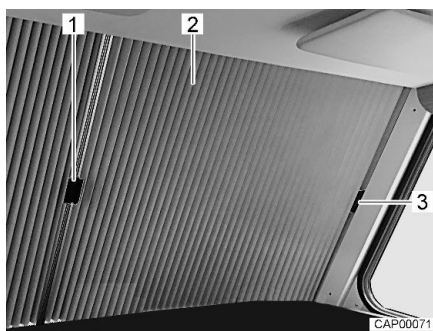


Fig. 2 Roman shade for windscreen (closed)

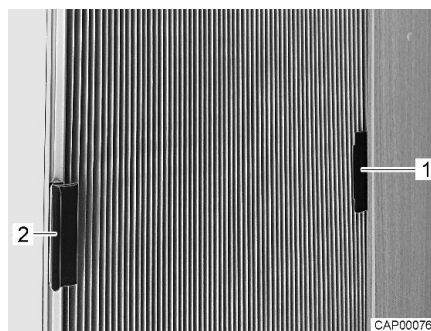


Fig. 3 Roman shade for side pane (closed)

Securing Roman shade (windscreen):

- Push the respective handle (Fig. 2,1) of both halves of the Roman shade (Fig. 2,2) outwards, underneath the cover on the A column.
- Fix the handles respectively by plugging them onto the cover (Fig. 2,3). Thus, the windscreen shade is secured against closing involuntarily during the journey.

Securing Roman shade (side panes):

- Push the handle (Fig. 3,1) of the Roman shade into the cap (Fig. 3,2). Thus, the Roman shade is secured against closing involuntarily.

4.6 PVC-floor covering



- ▶ Gas pipes and electric lines are laid in the floor. Never drill holes in the floor or insert any screws. That could cause a gas explosion, an electrical shock or a short circuit due to damage to a cable.



- ▷ Shoes with pointed heels can leave permanent impressions in the PVC-floor covering. Never wear shoes with pointed heels in the vehicle.
- ▷ Rubber mats or long exposure to ketchup, carrot juice, ink, blood or lipstick can discolour the PVC-floor covering. If possible, remove stains from the floor immediately.



4.7 Television



- ▶ Before commencing the journey, store the television securely.
- ▶ Before commencing the journey, ensure that the antenna is in park position. Danger of accidents! Park position means: The antenna points towards the back, is fully lowered and is locked in this position.

4.8 Branch block (model I)

The living area heater and the heater of the base vehicle can be coupled or disconnected from each other (via a branch block). When the heating circuits are coupled, you can for example heat the windscreen even when the vehicle is parked and, therefore, the heater of the base vehicle is not working.

It is recommended, though, to close the branch block during the journey and, thus, disconnect the heating circuits from each other. In this way, the full power of the heater of the base vehicle is available for the panes in the driver's cabin.

The sliding regulator for the branch block is located on the outside left of the dashboard.

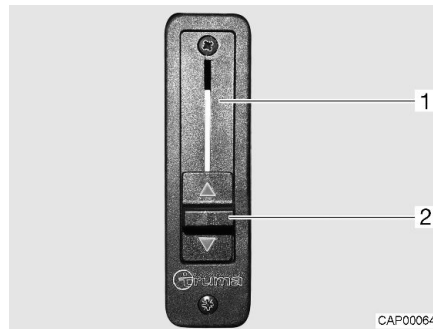


Fig. 4 Sliding regulator for branch block

Opening branch block:

- Push the sliding regulator (Fig. 4,2) fully upwards. The branch block (Fig. 4,1) is open. The living area heater also heats the windscreen.

Closing branch block:

- Push the sliding regulator (Fig. 4,2) fully downwards. The branch block is closed. The living area heater and the heater of the base vehicle are disconnected from each other.



4.9 Bonnet (model I)



- ▶ When the bonnet is open, there is a risk of injury in the engine compartment.
- ▶ Even if the engine was switched off some time ago, it might still be hot. Danger of burns!
- ▶ Do not work in the engine compartment while the engine is running.
- ▶ The bonnet must be kept firmly closed and locked during the journey. After closing, check whether the lock has engaged. In order to carry this out, pull on the bonnet.



Fig. 5 Release lever (bonnet)

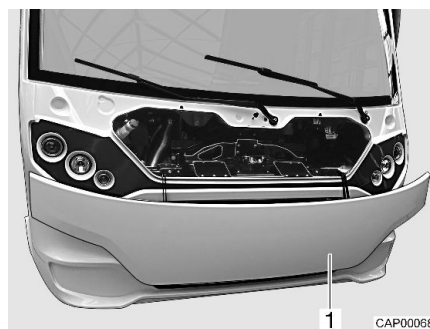


Fig. 6 Bonnet

- Opening:*
- Pull the release lever (Fig. 5, 1) situated on the left-hand side of the vehicle on the dashboard. The bonnet (Fig. 6, 1) opens.
 - Move the bonnet forwards and downwards in an arch.
- Closing:*
- Move the bonnet upwards in an arch.
 - Press down the centre of the bonnet until the catch lock engages audibly.
 - Check whether the bonnet is locked correctly. In order to carry this out, pull on the bonnet.

4.10 Filling in windscreen washer fluid (model I)

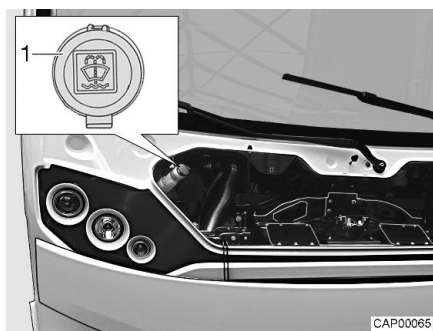


Fig. 7 Filler neck (windscreen washer fluid)

- Unlock and open the bonnet.
- Open the lid (Fig. 7, 1) on the filler neck of the washer fluid container.
- Carefully fill in windscreen washer fluid.
- Close the lid on the filler neck of the washer fluid container.
- Close the bonnet.



4.11 Checking engine oil level (model I)

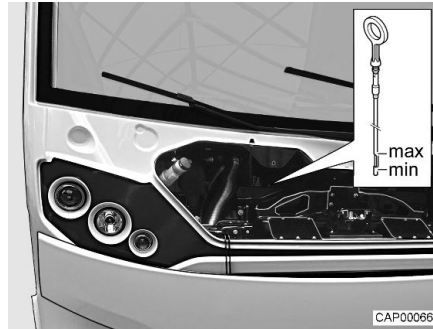


Fig. 8 Oil dipstick (engine oil)

The oil dipstick for the engine oil is located in the engine compartment, behind the front crossbeam. The oil dipstick is marked in red.



- ▷ Further information can be found in the instruction manual of the base vehicle.

4.12 Snow chains



- ▷ Only mount snow chains if there is a clearance of at least 50 mm between the tyres and the vehicle body.
- ▷ When using snow chains, the tyres, wheel suspension and steering are subjected to an additional load. When using snow chains, drive slowly (maximum speed 50 km/h) and only on streets which are completely covered with snow. Otherwise the vehicle could be damaged.
- ▷ Observe the fitting instructions issued by the manufacturer of the snow chains.
- ▷ Only use snow chains approved by the manufacturer.
- ▷ Do not fit snow chains on alloy wheel rims.

The use of snow chains is subject to the legal regulations of the individual countries.

- Always mount snow chains to the drive wheels.
- After a few metres, check the tension of the snow chains.



4.13 Road safety




- Check tyre pressure before a journey or every 2 weeks. Wrong tyre pressure causes excessive wear and can lead to damage or even to tyre burst. You can lose control of the vehicle (see section 14.6).

Before commencing the journey, work through the checklist:

No.	Checks	Checked	
Base vehicle	1	All vehicle documents are on board	
	2	Tyres in proper condition and tyre pressure correct	
	3	Vehicle lighting, brake lights and reversing lights function	
	4	Oil levels for engine, gearbox and power steering controlled	
	5	Coolant and fluid for windscreen washers filled up	
	6	Brakes function	
	7	Brakes react evenly	
	8	When braking, the vehicle remains in the lane	
Housing body, outside	9	Awning completely retracted	
	10	Roof free of snow and ice (in winter)	
	11	External connections and lines disconnected and stored away	
	12	External supports removed	
	13	Fitted steady legs retracted and fixed in place	
	14	Wheel chocks removed and stored away	
	15	Entrance step retracted (observe warning tone)	
	16	External flaps closed and locked	
	17	Conversion door locked	
	18	Awning light switched off	
	19	Overall height of the vehicle including roof rack when loaded measured and noted. Keep the height information close at hand in the driver's cabin	




Housing body, inside

No.	Checks	Checked
20	Windows and skylights closed and locked	
21	Television removed from the support and securely stored	
22	Television antenna retracted (if one is built in)	
23	Loose parts stored away or fixed in position	
24	Open storage spaces empty	
25	Sink cover is stored securely	
26	Refrigerator door secured	
27	Refrigerator set to 12 V operation	
28	All drawers and flaps closed	
29	Living area doors and sliding doors secured	
30	Children's seats mounted to seats with three-point safety belts  ► Only forward-facing child restraint systems are permitted.	
31	Swivel seat locking device for driver's seat and front passenger's seat locked	
32	Shades in the driver's cabin opened and secured	

Gas system

33	Gas bottles firmly fixed in the gas bottle compartment so that they are unable to turn	
34	If the gas bottles are not connected to the gas tube, always place the protective cap on top	
35	Regulator tap on the gas bottle and gas isolator taps are closed	

Electrical system

36	Check the battery voltage of the starter and living area battery (see chapter 9). If the panel indicates that the battery voltage is too low, the respective battery will need to be recharged. Observe the notes and instructions in chapter 9  ► Commence journey with fully charged starter and living area batteries.	
----	---	--





Chapter overview

This chapter contains instructions on how to drive the motorhome.

The instructions address the following topics:

- driving speed
- brakes
- seat belts
- seats and headrests
- seating arrangement
- writing and reading rest
- electrical window winder
- electrically adjustable external mirrors
- filling the tank

5.1 Driving the motorhome



- ▶ The base vehicle is a commercial vehicle (small truck). Adjust your driving technique accordingly.
- ▶ Before commencing the journey and after short interruptions of the journey, ensure that the entrance step is completely retracted.
- ▶ A seat belt is fitted for each seat which is permitted for travel. Please keep your seat belt fastened during the journey.
- ▶ Never open your seat belts when travelling.
- ▶ Passengers must remain in the seats provided.
- ▶ The doors must remain locked.
- ▶ Avoid braking with a jerk.
- ▶ If a navigation system is used, only change the destination when the vehicle is stationary. Drive to a car park or stop in a safe area when changing the destination.
- ▶ Do not play DVDs using the monitor of the navigation system during the journey.
- ▶ Always switch off outdoor light/awning light during the journey.



- ▷ Drive slowly on poor roads.
- ▷ Take extreme care when driving onto ferries, crossing uneven roads and driving in reverse. Because of the relatively large overhang, larger vehicles might swing out and "touch ground" in unfavourable conditions. This can cause damage to the underbody or to parts fitted there, e.g. a motorcycle rack.



- ▷ If an accident occurs as a result of these instructions not being observed, the manufacturer will not be responsible for damages caused.
- ▷ The safety measures stipulated in chapter 3 have to be observed.



5.2 Driving speed



- ▶ The vehicle is equipped with a powerful engine. This means there are sufficient reserves in difficult traffic situations. This high power enables a high maximum speed and requires above-average driving ability.
- ▶ The vehicle provides a large contact surface for wind. A sudden cross-wind can be especially dangerous.
- ▶ Uneven or one-sided loading affects road performance.
- ▶ Driving on unknown streets, you may encounter hazardous road conditions and unexpected driving situations. Therefore, in the interest of safety, make sure your driving speed is appropriate to any given driving situation and environment.
- ▶ Adhere to the national legal speed limits.

5.3 Brakes



- ▶ Have defects on the braking system immediately remedied by an authorised specialist workshop.



- ▷ Avoid block brakings. Block braking gives the tyres "brake plates" of varying strength. This reduces driving comfort. It might even make the tyres unserviceable.

Before each journey

Before each journey, check by means of a braking test:

- Do the brakes function?
- Do the brakes react evenly?
- Does the vehicle remain in the lane when braking?



5.4 Seat belts

The vehicle is equipped with seat belts in the living area on the seats for which seat belts are compulsory by law. National regulations apply to fastening of seat belts.



- ▶ Fasten your seat belts before the beginning of the journey and keep them fastened during the journey.
- ▶ Do not damage or trap belts. Have damaged seat belts changed by an authorised specialist workshop.
- ▶ Do not alter the belt fixing devices, automatic seat belt winders and the belt clips.
- ▶ Only use one seat belt for **one** adult person.
- ▶ Do not belt in objects together with persons.
- ▶ Seat belts are not sufficient for persons who are less than 150 cm tall. In these cases use additional restraining devices. Observe test certificate.
- ▶ Only attach the child restraint system to seats that are specified for this purpose. Only forward-facing child restraint systems are permitted.
- ▶ After an accident, replace the seat belts.
- ▶ During the journey, do not tilt the backrest too far backwards. Otherwise the functionality of the seat belt is no longer guaranteed.

5.4.1 Fastening the seat belt correctly



- ▶ Do not twist the belt. The belt must be positioned smoothly against the body.
- ▶ When fastening the seat belt, adopt the correct sitting position.

The seat belt is correctly fastened when the lap belt passes below your stomach and across the hip bone. The shoulder belt must pass across the chest and shoulder (not across your neck). The belt must always be taut against your body. Any bulky or padded clothing should therefore be removed before you start your journey.



5.5 Driver's seat and front passenger's seat



- ▶ Before commencing the journey, rotate all swivel seats in the direction of travel and lock in position.
- ▶ The seats must remain fixed in position during the journey and are not to be rotated.

The driver's seat and the front passenger's seat are part of the base vehicle. The adjustment of the seats is described in the operating manual of the base vehicle.

5.6 Headrests

Before commencing the journey, adjust the headrests so that the back of the head is supported at approximately ear height.

5.7 Seating arrangement



- ▶ During the journey, persons are only to sit on the permitted seats. The authorised number of seats is stipulated in the vehicle documents.
- ▶ During the journey sitting on the divans is not permitted.
- ▶ Seat belts must be worn by all passengers.



Fig. 9 "Seat" symbol



Fig. 10 Symbol "Do not use seat during the journey"

Seats which may be used during travel are equipped with a sticker (Fig. 9). Seats which may not be used during the journey are equipped with a sticker (Fig. 10).



5.8 Tablet holder



- ▶ If the driver's attention is distracted from the road, there is a danger of accidents. Do not install or operate the tablet or the smartphone during the journey.



Fig. 11 Tablet holder

A folding tablet holder is installed at the centre of the dashboard. The tablet holder is suitable for tablets and smartphones with a display size of 10" as well as for notepads.

Fold the tablet holder if you are not using it.



- ▶ Further information can be found in the instruction manual of the base vehicle.

5.9 Electrical window winder



- ▶ Remove hands and other objects from the window before closing.
- ▶ Even if you leave your vehicle just briefly, remove the ignition key from the steering lock. Otherwise children may be able to operate the window winder and injure themselves.

There is an electrical window winder on the driver's side of the vehicle.

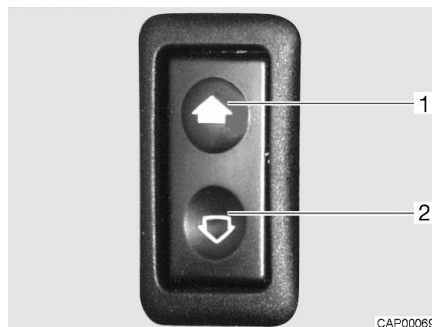


Fig. 12 Switch (electrical window winder)

- Opening:* ■ Press the lower part of the switch (Fig. 12,2).
- Closing:* ■ Press the upper part of the switch (Fig. 12,2).



5.10 Electrically adjustable external mirrors

Depending on the model, the vehicle is equipped with two electrically adjustable and heated external mirrors. The switches for external mirror adjustment and the mirror heater are on the dashboard.

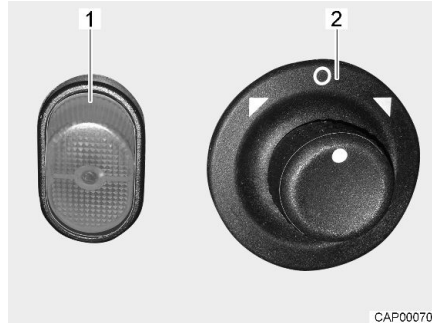


Fig. 13 Switch (electrically adjustable external mirrors)

Adjusting the mirror:

- Select the mirror to be adjusted. To do so, turn the rotary switch (Fig. 13,2) to the left or right.
- Adjust the mirror. In order to do this, push the switch (Fig. 13,2) towards the desired direction.

Switching on the heater:

- Press the switch (Fig. 13,1). The indicator lamp in the switch glows orange and indicates that the mirror heater is in operation.

5.11 Filling up with diesel



- ▶ All gas-operated devices (heater, cooker, oven, grill, refrigerator - depending on the equipment) must be switched off for refuelling, on ferries or in the garage. Danger of explosion!

The fuel filler neck is situated on the exterior of the vehicle, at the front left.



Chapter overview

This chapter contains instructions on how to pitch the vehicle.

The instructions address the following topics:

- handbrake
- entrance step
- operation of the supports
- 240 V connection
- refrigerator



- ▷ Pitch the vehicle so that it is as horizontal as possible. Use ramps where necessary. Otherwise, the water from the shower tray will not be able to drain properly.
- ▷ Secure the vehicle to prevent it from rolling.
- ▷ Animals (especially mice) can cause great damage to the interior of the vehicle. To prevent this from happening, regularly check the vehicle for damages or animal traces after pitching.

6.1 Handbrake

Firmly apply the handbrake when parking the vehicle.



- ▷ If there is any risk of frost, release the handbrake every now and then and apply it again. This will prevent it from freezing or rusting. Prior to releasing the handbrake, secure the vehicle so that it cannot roll away.

6.2 Entrance step

In order to exit the vehicle, first fully extend the entrance step.

Not present in the model I due to the coupé entry.

6.3 Ramps



- ▷ Ramps are not included in the scope of delivery. Different models are available from accessory shops.

To enable the vehicle to be parked on the level, ramps can be used for height compensation when the vehicle is parked on a hill or on uneven ground.

6.4 Supports

6.4.1 General instructions



- ▷ Do not use the fitted supports as a vehicle jack. They supports are only for stabilising the parked vehicle to prevent the rear axle from bottoming out.
- ▷ When pitching the vehicle, ensure that the supports are evenly loaded.
- ▷ Before driving away, wind up the supports as far as they can go, fully retract and secure them.



- ▷ When the ground is soft, place a pad or block under the supports in order to prevent the vehicle from sinking into the ground.



6.4.2 Steady legs



- ▷ Depending on the model, the hexagonal nut has a joint, which can be used to bring the attached socket spanner into a more convenient position for turning.

In order to ensure their correct function, clean and grease the interior tubes of the steady legs regularly.

The length of the steady legs can be adjusted according to the model.

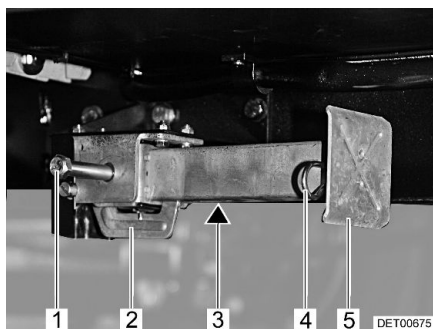


Fig. 14 Steady leg

- Extending:*
- Place the socket spanner on the hexagon nut (Fig. 14,1) and rotate until the steady leg is in a perpendicular downward position.
 - If the length of the steady leg can be adjusted, remove the splint (Fig. 14,4) out of the support foot extension (Fig. 14,5).
 - Pull out the support foot extension until it has reached the required length.
 - Insert the splint in the support foot extension.
 - Rotate the hexagonal nut until the steady leg rests completely on the ground and the vehicle is in a horizontal position.
- Retracting:*
- Place the socket spanner on the hexagon nut (Fig. 14,1) and rotate until the steady leg is clear of the ground.
 - If the length of the steady leg can be adjusted, remove the splint (Fig. 14,4) out of the support foot extension (Fig. 14,5).
 - Push in the support foot extension (Fig. 14,5) and insert the splint (Fig. 14,4) in the drilled hole in the support foot extension.
 - Rotate the hexagonal nut (Fig. 14,1) until the steady leg has swung upwards and the guide (Fig. 14,2) has reached the very end of the slot (Fig. 14,3).



- ▷ Before commencing the journey, observe the following: Are all steady legs and support foot extensions retracted completely and secured with the splint?

6.5 240 V connection

The vehicle can be connected to a 240 V power supply (see chapter 9).

6.6 Refrigerator

The 12 V operation of the refrigerator is only possible when the vehicle engine is running. When the vehicle engine is switched off, switch the refrigerator to 240 V operation or gas operation.



Chapter overview

This chapter contains instructions about living in the vehicle.

The instructions address the following topics:

- opening and closing the doors and external flaps
- ventilation of the vehicle
- opening and closing the windows and blinds
- opening and closing the skylights
- converting tables
- lamps
- use of the beds

7.1 Doors



▶ Only drive with locked doors.



- ▷ Locking the doors can prevent them from opening of their own accord, e.g. during an accident.
- ▷ Locked doors also prevent forced entry, e.g. when waiting at traffic lights. However, in an emergency, locked doors make it more difficult for helpers to enter the vehicle.
- ▷ When leaving the vehicle, always lock the doors.
- ▷ Depending on the model, the locks of the driver's and the passenger's doors are part of the base vehicle. For these models, the opening and closing of the driver's door and the front passenger's door is described in the instruction manual of the base vehicle.

7.1.1 Driver's door, conversion door, outside

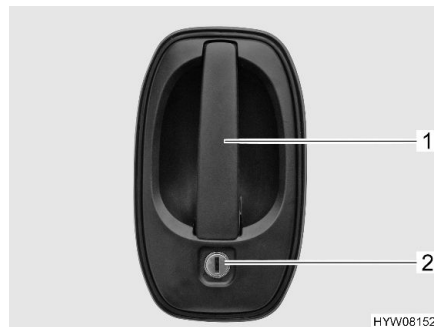


Fig. 15 Door lock (driver's door, conversion door, outside)

- Opening:**
- Insert the key into locking cylinder (Fig. 15,2) and turn until the door lock is unlatched.
 - Return the key to the central position and remove it.
 - Pull on the handle (Fig. 15,1). The door is open.
- Locking:**
- Insert the key into locking cylinder (Fig. 15,2) and turn until the door lock is engaged.
 - Return the key to the central position and remove it.



7.1.2 Conversion door, inside

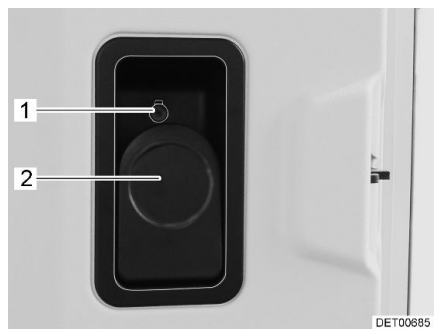


Fig. 16 Door lock of conversion door, inside, locked

Opening: ■ Pull lever (Fig. 16,2).

Locking: ■ Push the safety knob (Fig. 16,1) in.

7.1.3 Driver's door, inside (model I)

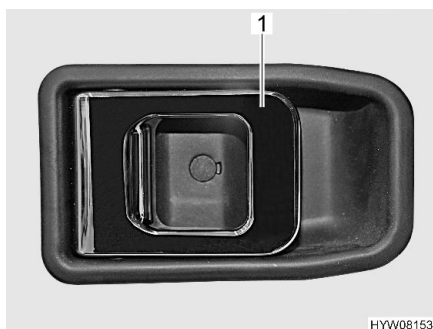


Fig. 17 Door lock (driver's door, inside)

Opening: ■ Pull on the handle (Fig. 17,1). The door lock is unlatched.

Locking: ■ Press handle (Fig. 17,1) into the handle shell. The door lock is locked.



7.1.4 Insect screen on the conversion door, extendable



- ▷ Open the insect screen completely before closing the conversion door.



Fig. 18 Insect screen

- Closing:*
- Pull out the insect screen completely by the bar (Fig. 18,1).
- Opening:*
- Push the insect screen into its initial position by the bar (Fig. 18,1).

7.2 External flaps



- ▷ Before commencing the journey, close all external flaps and lock them.
- ▷ To open and close the external flap, open or close all locks that are fitted to the external flap.



- ▷ When leaving the vehicle, close all external flaps.

The external flaps fitted to the vehicle are all fitted with identical locking cylinders. Therefore, all locks can be opened with a single key.



7.2.1 Flap lock, elliptical-shaped



- ▷ During rain, water can penetrate the opened flap lock. Therefore close the lock handle.

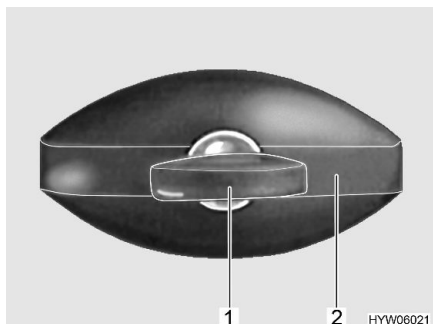


Fig. 19 Flap lock (elliptical-shaped, closed)

- Opening:*
- Insert key into locking cylinder (Fig. 19,1) and turn a quarter turn in an anti-clockwise direction. The lock handle (Fig. 19,2) snaps out.
 - Remove the key.
 - Turn lock handle one quarter turn in an anticlockwise direction. The flap lock is open.

- Closing:*
- Firmly close the external flap.
 - Turn lock handle in a clockwise direction until it is horizontal. The flap lock is now engaged but not locked.
 - Insert key into locking cylinder.
 - Press down lock handle with key inserted and turn key a quarter turn in a clockwise direction. The lock handle will stay bolted.
 - Remove the key.

7.3 Ventilation



- ▶ The oxygen in the vehicle interior is used up by breathing and the use of gas operated appliances. That is why the used air must be replaced permanently. For this purpose, forced ventilation options (e.g. skylights with forced ventilation) are fitted to the vehicle. Never cover or block forced ventilations from the inside or outside with objects such as e.g. a winter mat. Keep forced ventilations clear of snow and leaves. There is a danger of suffocation due to increased CO₂ levels.



- ▷ Although sufficient ventilation is provided, in certain weather conditions, condensation can form on metal objects (e.g. screwed connections in the floor).
- ▷ Additional cold spots can occur at thermal "bridges" (e.g. skylight edges, filler necks, flaps, etc.).

**Condensation**

Ensure that there is a continuous exchange of air by providing frequent and efficient ventilation. This is the only method for ensuring that condensation is not formed during cool weather. During the colder season, a pleasant living climate is created if heating output, air distribution and ventilation are synchronised. To avoid draft close the air outlet nozzles on the dashboard and set the air distribution of the base vehicle to air circulation. If the vehicle is laid up for a longer period, occasionally ventilate it well, especially in summer as heat accumulation can occur.

7.4 Windows

- ▷ The windows are fitted with a blind and an insect screen. After the latch has been released, the blind and insect screen automatically spring back to the initial position by tensile force. In order not to damage the tension mechanics, hold onto the blind or insect screen and allow it to slowly return to the initial position.
- ▷ Do not keep blinds closed over a longer period of time as that can cause increased material wear.
- ▷ If the blind is completely closed, exposure to direct sunlight can cause heat to accumulate between the blind and the glass window. The window could be damaged. For that reason, close the blind only 2/3 of the way in direct sunlight.
- ▷ Before commencing the journey, close the windows.
- ▷ Depending on the weather, close the windows far enough to prevent moisture from entering.
- ▷ To open and close the hinged window, open or close all catch levers which are fitted to the hinged window.



- ▷ When leaving the vehicle, always close the windows.
- ▷ In extreme weather conditions or if the temperature fluctuates strongly, a light condensation film can form on the double-glazed acrylic glass. The glass is designed in such a way that condensation can evaporate when the external temperature increases. There is no danger of the double-glazed acrylic glass being damaged by condensation.

7.4.1 Sliding window without lock

Fig. 20 Sliding window without lock

- Opening:**
- Pull handle flap (Fig. 20,1) and push or pull handle forward at the same time.
 - Open window half up to the required position.
- Closing:**
- Close the window as far as possible and let the handle lock in place.



7.4.2 Hinged window with automatic hinges



- ▷ Open the window completely, to release the lock. If the locking device is not released and the window is closed nevertheless, there is the danger of the window breaking due to the massive counter-pressure.
- ▷ When opening the hinged windows, ensure that there are no torsional forces. Open and close the hinged windows evenly.
- ▷ If the catch lever is equipped with a safety knob, press the safety knob when operating the catch lever.

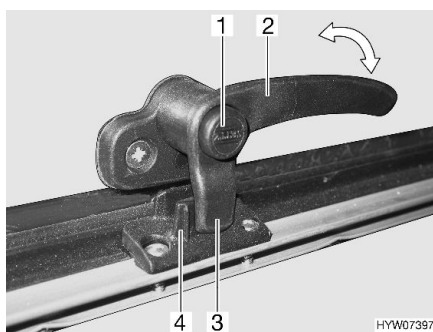


Fig. 21 Catch lever in "closed" position



Fig. 22 Hinged window with automatic hinges

- Opening:**
- Press the safety knob (Fig. 21,1) and keep it pressed.
 - Turn the catch lever (Fig. 21,2) a quarter turn towards the centre of the window.
 - Open the hinged window to the desired latched position. The automatic hinge (Fig. 22,1) locks in place automatically.

The hinged window remains locked in the required position.

- Closing:**
- Open the hinged window as wide as is necessary to release the lock.
 - Close the hinged window.
 - Press the safety knob (Fig. 21,1) and keep it pressed.
 - Turn the catch lever (Fig. 21,2) a quarter turn towards the window frame. The locking catch (Fig. 21,3) on the catch lever is entirely on the inner side of the window catch (Fig. 21,4).

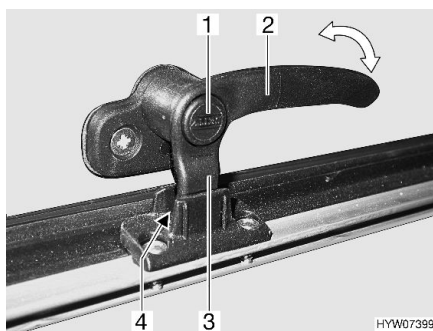


Fig. 23 Catch lever in the "continuous ventilation" position

Continuous ventilation

With the catch lever, the hinged window can be placed in two positions:

- "Continuous ventilation" (Fig. 23)
- "Firmly closed" (Fig. 21)



To place the hinged window into the "continuous ventilation" position:

- Press the safety knob (Fig. 23,1) and keep it pressed.
- Turn the catch lever (Fig. 23,3) a quarter turn towards the centre of the window.
- Lightly open the hinged window outwards.
- Return the catch lever to its initial position. Move the locking catch (Fig. 23,3) on the catch lever into the recess of the window catch (Fig. 23,4).
- Release the safety knob (Fig. 23,1).
- Make certain that the safety knob is not pushed in but rather that it secures the catch lever.

During the journey, the hinged window may not be in "continuous ventilation" position.

If it rains, the "continuous ventilation" hinged window position could lead to splashing water penetrating the living area. Therefore, close the hinged windows completely.

7.4.3 Roman shade for windscreen and side panes

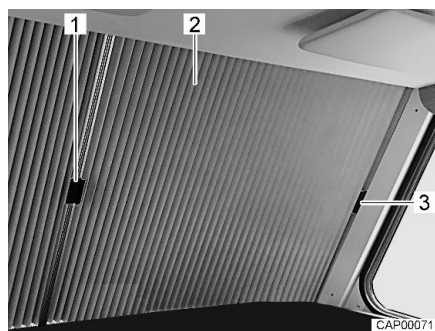


Fig. 24 Roman shade for windscreen (closed)

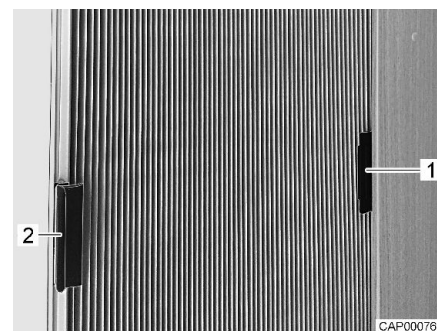


Fig. 25 Roman shade for side pane (closed)

Closing Roman shade (windscreen):

- Pull the respective handle (Fig. 24,1) of both halves of the Roman shade (Fig. 24,2) carefully towards the centre of the windscreen until the magnetic catch holds the Roman shade in closed position.

Opening Roman shade (windscreen):

- Push the respective handle (Fig. 24,1) of both halves of the Roman shade (Fig. 24,2) outwards, underneath the cover on the A column.
- Fix the handles respectively by plugging them onto the cover (Fig. 24,3).

Closing Roman shade (side pane):

- Close the Roman shade by pulling the respective handle (Fig. 25,1).

Opening Roman shade (side pane):

- Push the handle (Fig. 25,1) of the Roman shade into the cap (Fig. 25,2).



7.4.4 Blind and insect screen



- ▷ Open blinds before commencing the journey. When the blinds are closed, vibrations can damage the spring shaft.



- ▷ Depending on the window size, the blinds are fitted with one or two handles.

The windows are fitted with a blind and an insect screen. The blind and insect screen are adjusted separately.

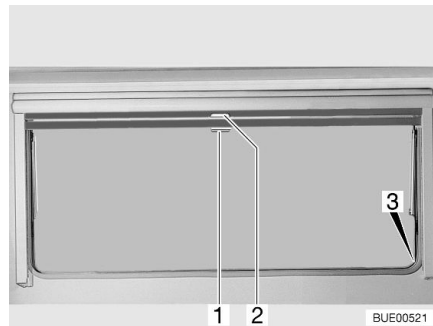


Fig. 26 Hinged window

Blind The blind is located in the upper blind box.

- Closing:**
- Pull blind at the handle (Fig. 26,2) downwards. If the blind is to be completely closed, it is suspended into the locking devices (Fig. 26,3) situated on both sides of the window frame.
- Opening:**
- If the blind is completely closed: Press handle (Fig. 26,2) downwards and, at the same time, tilt it slightly inward. The blind can be taken out of the locking devices situated on both sides of the window frame.
 - If the blind is in an intermediate position: Pull the handle (Fig. 26,2) slightly downwards until the locking device releases.
 - Use handle to return blind slowly to its initial position.

Insect screen The insect screen is located in the upper blind box.

- Closing:**
- Pull insect screen at the handle (Fig. 26,1) down and hang it into the locking devices (Fig. 26,3) situated on both sides of the window frame.
- Opening:**
- Press handle (Fig. 26,1) downwards and, at the same time, tilt it slightly inward. The insect screen can be taken out of the locking devices situated on both sides of the window frame.
 - Use handle to return the insect screen slowly to its initial position.



7.4.5 Sunroof with rotary hinges



- ▷ When opening the sunroof, ensure that there are no torsional forces. Open and close the sunroof evenly.

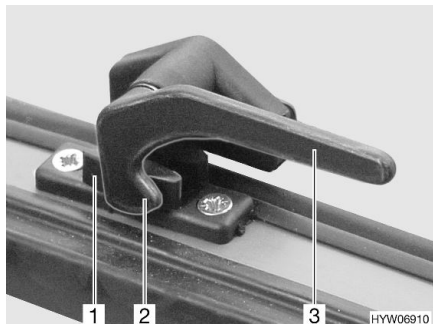


Fig. 27 Catch lever in "closed" position

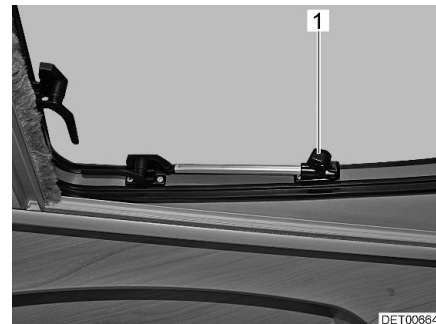


Fig. 28 Sunroof with rotary hinges, open

Opening:

- Turn the catch lever (Fig. 27,3) a quarter turn towards the centre of the window.
- Open the sunroof until the required position has been reached and use knurled knob (Fig. 28,1) to secure in position.

The sunroof remains locked in the required position.

Closing:

- Turn knurled knob (Fig. 28,1) until the latch is released.
- Close the sunroof.
- Turn the catch lever (Fig. 27,3) a quarter turn towards the window frame. The locking catch (Fig. 27,2) is located on the inside of the window catch (Fig. 27,1).

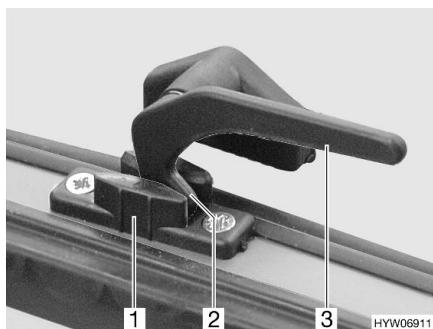


Fig. 29 Catch lever in the "continuous ventilation" position

Continuous ventilation

With the catch lever, the sunroof can be placed in 2 positions:

- "Continuous ventilation" (Fig. 29)
- "Firmly closed" (Fig. 27)



To place the sunroof into the "continuous ventilation" position:

- Turn the catch lever (Fig. 29,3) a quarter turn towards the centre of the window.
- Slightly open the sunroof outwards.
- Return the catch lever to its initial position. The locking catch (Fig. 29,2) has to be moved into the recess of window catch (Fig. 29,1).

During the journey, the sunroof may not be in "continuous ventilation" position. If it rains, the "continuous ventilation" sunroof position could lead to splashing water penetrating the living area. Therefore, close the sunroof completely.

7.4.6 Roman shade and insect screen

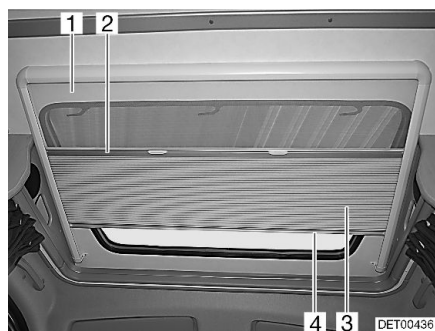


Fig. 30 Sunroof

Roman shade The Roman shade (Fig. 30,3) is permanently connected to the insect screen (Fig. 30,1).

- Closing:*
- Hold the Roman shade in the centre of the bottom rod (Fig. 30,4) and carefully draw it downwards.
 - Release the Roman shade at the desired position. The Roman shade will stay in that position.
- Opening:*
- Slowly return the Roman shade to its initial position with the bottom rod (Fig. 30,4).

Insect screen The insect screen is permanently connected to the Roman shade. When the insect screen is opened, the Roman shade is opened along with it.

- Closing:*
- Hold the insect screen at the centre of the bottom rod (Fig. 30,2) and carefully pull it downward as far as it goes.
- Opening:*
- Slowly return the insect screen on the bottom rod of the Roman shade (Fig. 30,4).



7.5 Skylights

Depending on the model, skylights with or without forced ventilation are fitted to the vehicle. If a skylight is fitted without forced ventilation, the forced ventilation is performed using mushroom-shaped vents.



- ▶ The apertures for forced ventilation must always be kept open. Never cover or block forced ventilations with objects such as e.g. a winter mat. Keep forced ventilations clear of snow and leaves.



- ▷ The skylights are equipped with an insect screen and, depending on the model, a blind or a Roman shade. After the latch has been released, the blind automatically springs back to the initial position by tensile force. In order not to damage the tension mechanics, hold onto the blind and allow it to slowly return to the initial position.
- ▷ Do not keep blinds closed over a longer period of time as that can cause increased material wear.
- ▷ If the blind or the Roman shade is completely closed, exposure to direct sunlight can cause heat to accumulate between the blind/the Roman shade and the skylight. The skylight could be damaged. For that reason, close the blind/Roman shade only 2/3 of the way in direct sunlight. Open the skylight slightly or move it to ventilation position.
- ▷ Depending on the weather, close the skylights far enough to prevent moisture from entering.
- ▷ Do not climb on the skylights.
- ▷ Before commencing the journey, close the skylights.
- ▷ Before commencing the journey, check that the skylights are closed and locked.
- ▷ Treat seals on the skylights with a conventional rubber care product at least once a year.
- ▷ During the first annual inspection, the inside frame of the skylight must be removed and the screw connections of the securing clips tightened. The vehicle owner is responsible for seeing that this is carried out.



- ▷ When leaving the vehicle, always close the skylights.



7.5.1 Skylight with snap latch

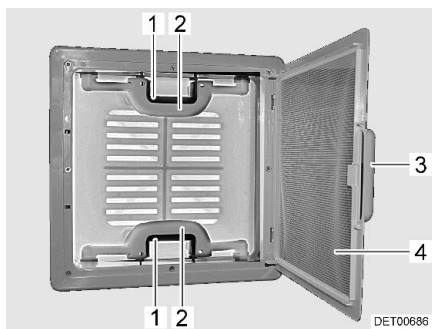


Fig. 31 Skylight with snap latch

The skylight can be pushed upwards either from one side or from both sides.

- Opening:**
- Pull on the handle (Fig. 31,3).
 - Fold insect screen (Fig. 31,4) downward.
 - Push the snap latch (Fig. 31,1) towards the inside of the skylight. At the same time use the handle (Fig. 31,2) to press the skylight upwards.
 - Swing insect screen (Fig. 31,4) upwards until it latches in place.

- Closing:**
- Pull on the handle (Fig. 31,3).
 - Fold insect screen (Fig. 31,4) downward.
 - Using both handles (Fig. 31,2), pull down the skylight with force until the two snap latches (Fig. 31,1) lock into place.
 - Swing insect screen (Fig. 31,4) upwards until it latches in place.

Blind Depending on the equipment, the skylight will be equipped with a blind. To close and open the blind:

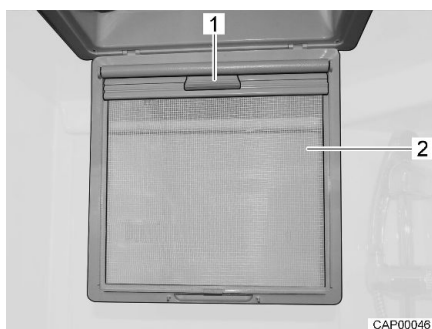


Fig. 32 Blind

- Closing:**
- Pull on the handle (Fig. 31,3).
 - Fold insect screen (Fig. 32,2) downward.
 - Pull blind down by the handle (Fig. 32,1) until it engages on the opposite side.

- Opening:**
- Release blind at the handle (Fig. 32,1) and return it slowly to its initial position.
 - Swing insect screen (Fig. 32,2) upwards until it latches in place.

**Forced ventilation**

Depending on the equipment, the skylight will be equipped with a forced ventilation (Fig. 33,1). The skylights with forced ventilation are installed in the living area and in the toilet compartment.

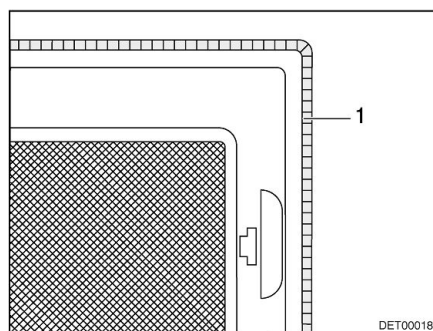


Fig. 33 Forced ventilation

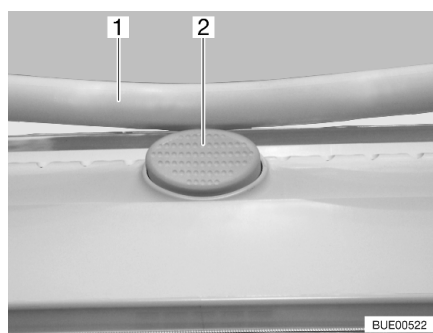
7.5.2 Heki skylight (mini and midi)

Fig. 34 Safety knob on the Heki skylight

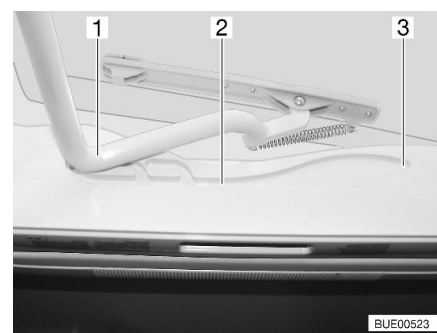


Fig. 35 Heki skylight, guide

The Heki skylight is opened on one side only.

Opening:

- Press the safety knob (Fig. 34,2) and pull the bar (Fig. 34,1) down with both hands.
- Pull the bar (Fig. 35,1) in the guides (Fig. 35,2) to the rearmost position (Fig. 35,3).

Closing:

- Use both hands to push the bar (Fig. 35,1) slightly upwards.
- Push the bar back in the guides.
- Push the bar upwards with both hands until it is above the safety knob (Fig. 34,2).

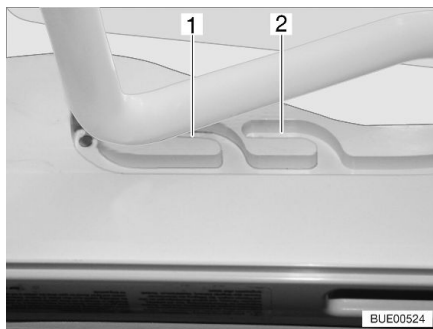


Fig. 36 Heki skylight in ventilation position

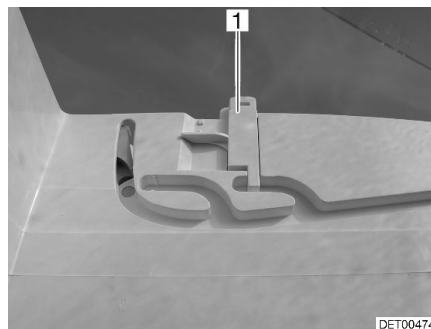


Fig. 37 Ventilation position locking mechanism

Ventilation position

The Heki skylight can be put in two ventilation positions: Bad weather position (Fig. 36,1) and central position (Fig. 36,2). Depending on the model, the skylight can be locked in the central position with both left and right latches (Fig. 37,1) on the skylight frame.

- Press the safety knob (Fig. 34,2) and pull the bar (Fig. 34,1) down with both hands.
- Pull the bar in the guides (Fig. 35,2) to the desired position.
- Push the bar slightly upwards and into the selected guide (Fig. 36,1 or 2) and lock if necessary.

Roman shade

To close and open the Roman shade:

- Closing:*
- Pull out Roman shade at the handle and release in the required position. The Roman shade will stay in that position.
- Opening:*
- Slowly push the Roman shade at the handle to its initial position.

Insect screen

To close and open the insect screen:

- Closing:*
- Pull the insect screen by the handle to the opposite handle of the Roman shade.
- Opening:*
- Press the rear part of the handle of the insect screen. The latch is released.
 - Use handle to return the insect screen slowly to its initial position.



7.6 Tables

7.6.1 Suspension table with fold-out leg

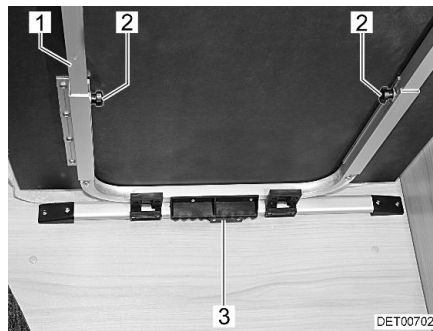


Fig. 38 Moving/extending the suspension table



Fig. 39 Table top extension

Moving the table in the direction of travel:

- Raise the front of the table top until the detent mechanism (Fig. 38,3) on the retainer is free.
- Move the table forwards or backwards (looking in the direction of travel).
- Lower the table top in the desired position and place it on the table leg.

The suspension table size can be enlarged by inserting a table top extension (Fig. 39,1).

Extending:

- Loosen the knurled screws (Fig. 38,2).
- Lift the table top slightly and pull out as far as possible. The table extension (Fig. 38,1) is fully extended.
- Set down the table.
- Insert the table top extension (Fig. 39,1) into the table extension.
- Lift the table top slightly and push back as far as possible.
- Tighten the knurled screws.

Reducing size:

- Loosen the knurled screws (Fig. 38,2).
- Slightly lift the front of the table top and pull out.
- Remove the table top extension (Fig. 39,1) and store it securely.
- Lift the table top slightly and push back as far as possible. The table extension (Fig. 38,1) is fully retracted.
- Set down the table.
- Tighten the knurled screws.

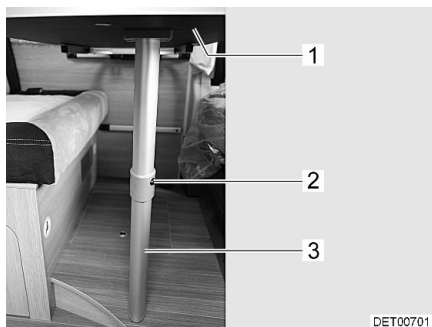


Fig. 40 Bed foundation

The table's fold-out leg enables it to be used as a bed foundation.

Conversion to bed foundation:

- Slightly raise the front of the table top (Fig. 40,1).
- Press the release knob (Fig. 40,2) and fold the lower part of the fold-out leg (Fig. 40,3) by 90°.
- Swivel the table top approx. 45° upward and remove the table from the retainer.
- Insert the table into the lower retainer and rest it on the table leg hinge.

7.6.2 Lift-off table

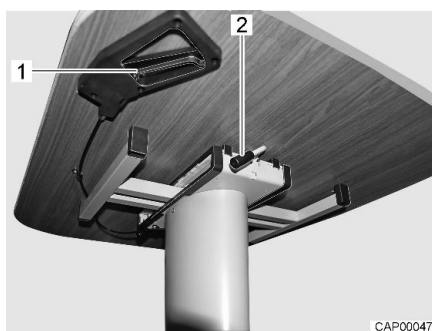


Fig. 41 Moving the lift-off table

Moving the table:

- Swivel lever (Fig. 41,2) downwards until it is in a downward vertical position.
- Move the table top to the desired position.
- Swivel lever (Fig. 41,2) upwards until the table top is fastened.

Adjusting table height, conversion to bed foundation:

- Pull the locking handle (Fig. 41,1).
- Push the table top downwards to the desired height. Without any pressure, the table top will slide upwards by spring force.
- Release the locking handle (Fig. 41,1). The table top remains at the adjusted height.



7.7 Lamps



- ▶ The light switches have different layouts according to the model. The light switches are located either in the entrance area, directly on the corresponding lamp or next to the lamp, e.g. in the vicinity of the seating group.

7.7.1 LED lamp (model I)

The LED lamps for the pull-down bed are installed on the ceiling above the pull-down bed.



Fig. 42 LED lamp with touch operation

Switching LED lamp on/off:

- Touch the LED lamp (Fig. 42). The LED lamp is switched on.
- Touch the LED lamp again. The LED lamp is switched off.

7.8 TV unit



- ▶ Before commencing the journey, bring the flat screen and screen holder into the driving position.



- ▶ The information about the operation of the TV unit can be obtained in the manufacturer's instruction manual.

Flat screen in the TV compartment

The flat screen is attached to a console in the TV compartment above the refrigerator.

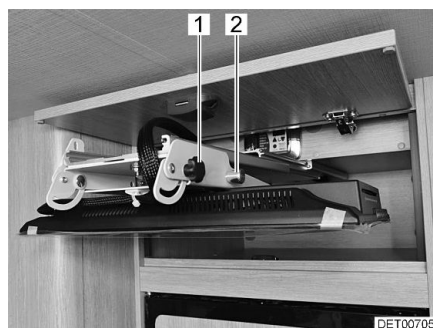


Fig. 43 Flat screen in the TV compartment



Fig. 44 Flat screen in television position

Bringing the flat screen into the television position:

- Open the TV compartment.
- Pull the flat screen horizontally out of the TV compartment.



- Hold the flat screen and pull the catch pin (Fig. 43,2).
- Swivel the flat screen downward into the desired position. If it is hard to move the flat screen, open the adjustment knobs (Fig. 43,1) slightly on both sides of the holder.
- Rotate the flat screen into the desired position. Tighten the adjustment knobs (Fig. 44,1) by hand.

Bringing the flat screen into the driving position:

- Rotate the flat screen until it is parallel to the cabinet front.
- Open the adjustment knobs (Fig. 44,1) slightly on both sides of the holder.
- Swivel the flat screen upwards while pulling the catch pin (Fig. 43,2).
- When the flat screen is touching the bracket, release the catch pin (Fig. 43,2). The catch pin must engage in the hole of the holder.
- Push the flat screen horizontally into the TV compartment as far as it will go.
- Close the TV compartment.

Flat screen on cabinet wall

The flat screen is attached to a pull-out inside or outside of the cabinet wall. Depending on the position, the catch spring will be located on the top or the bottom.



Fig. 45 Flat screen in driving position

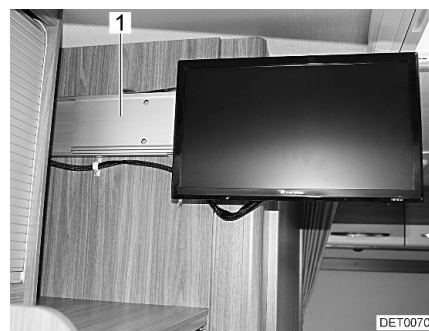


Fig. 46 Flat screen in television position

Bringing the flat screen into the television position:

- Release the catch spring (Fig. 45,1).
- Pull the flat screen out horizontally toward the centre of the vehicle.
- Rotate the flat screen into the desired position.

Bringing the flat screen into the driving position:

- Rotate the flat screen until it is parallel to the cabinet wall.
- Push the flat screen horizontally into the holder (Fig. 46,1) as far as it will go. The catch spring (Fig. 45,1) engages audibly.



7.9 Beds

7.9.1 Overcab bed



- ▶ The maximum permitted overcab bed load is 200 kg.
- ▶ Only use the overcab bed, if the safety net is set up.
- ▶ Never allow small children to remain in the overcab bed without supervision.
- ▶ But in particular with regard to small children less than 6 years of age, users should ensure that they cannot fall out of the overcab bed.
- ▶ Use separate children's beds or travel cots suitable for children.



- ▷ Do not load the overcab bed without mattress. The plastic mould part can break!

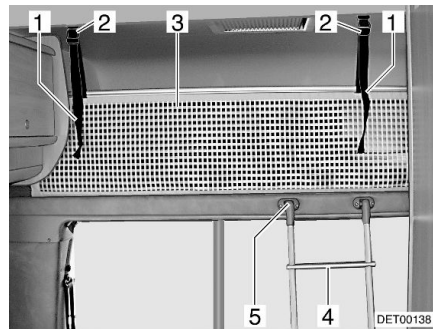


Fig. 47 Overcab bed

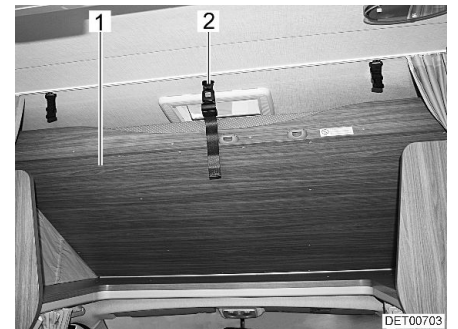


Fig. 48 Overcab bed in driving position

Access ladder

Always use the access ladder (Fig. 47,4) provided as standard to access the overcab bed.

Attaching:

- Attach the ladder with the rails to the holder (Fig. 47,5) on the alcove panel.

Safety net

The safety net (Fig. 47,3) is stored as standard between the mattress and slatted frame. Only use the safety net if persons are already in the alcove.

Setting up:

- Fasten the retaining straps (Fig. 47,1) to the holders on the ceiling (Fig. 47,2).

Driving position of overcab bed

It is recommended to place the overcab bed in driving position before setting off.

- Swivel the overcab bed (Fig. 48,1) upwards and let the retaining strap (Fig. 48,2) engage in the holder on the ceiling.



7.9.2 Pull-down bed



- ▶ The maximum permitted load on the pull-down bed is 250 kg.
- ▶ Load the two cupboards beneath pull-down bed, right and left (if present), with a maximum of 5 kg each.
- ▶ The pull-down bed is not to be used for the storage of luggage. When the bed is not being used, only place the bed linen which is required for two persons in it.
- ▶ Before commencing the journey, make sure that the pull-down bed has engaged in the lock.
- ▶ Only use the pull-down bed, if the safety guard is set up.
- ▶ Never allow small children to remain in the pull-down bed without supervision.
- ▶ But in particular with regard to small children less than 6 years of age, users should ensure that they cannot fall out of the pull-down bed.
- ▶ Use separate children's beds or travel cots suitable for children.
- ▶ Switch off the reading lamps on the underside of the pull-down bed when the bed is lowered. Fire hazard!
- ▶ Switch off the reading lamps in the pull-down bed before the bed is pushed up. Fire hazard!



- ▷ The pull-down bed is equipped with a lock for the top (closed) final position.



Fig. 49 Pull-down bed with lock



Fig. 50 Pull-down bed (model I)

The pull-down bed is located above the front seating group.

Model I The rests of the driver's and front passenger's seats must be tipped forwards before the pull-down bed is lowered. To do this, proceed as follows:

- Turn the driver's and the front passenger's seat to the direction of travel, lock it in place and move them backwards.
- Unlock the backrest and fold it fully forwards.
- Close the shade in the driver's cabin.

**Opening the pull-down bed:**

- Switch off the lamps on the underside of the pull-down bed.
- Push the driver's seat and the front passenger's seat all the way forward.
- Fold over the back cushion of the divan.
- Open the lock (Fig. 49,1).
- Use both hands to pull the pull-down bed down as far as it will go.

Closing the pull-down bed:

- Switch off the reading lamps in the pull-down bed.
- Loosen the retaining straps of the safety nets and lay the safety nets under the mattress.
- Use both hands to push pull-down bed upwards as far as it will go.
- Make sure that the lock has engaged audibly.

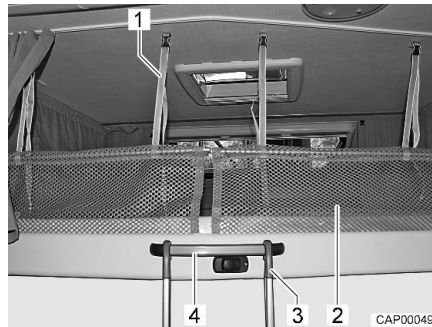


Fig. 51 Access ladder and safety net

Access ladder

Always use the access ladder provided as standard to access the pull-down bed.

Attaching:

- Hook the access ladder (Fig. 51,3) to the pull-down bed by attaching the two hooks to the curved handle (Fig. 51,4).

Safety net

The safety nets (Fig. 51,2) with the retaining straps are stored under the mattress. Only use the safety nets if persons are already in the pull-down bed.

Setting up:

- Fasten the retaining straps (Fig. 51,1) to the holders on the ceiling.

7.9.3 Bunk bed



- ▶ The maximum permitted bunk bed load is 100 kg.
- ▶ Only use the upper bunk bed if the safety guard is fitted.
- ▶ Never allow small children to remain in the bunk bed without supervision.
- ▶ But in particular with regard to small children less than 6 years of age, users should ensure that they cannot fall out of the bunk bed.
- ▶ Use separate children's beds or travel cots suitable for children.

Depending on the model, the rear area is fitted with a bunk bed. The bunk bed can also be used as a rear garage.

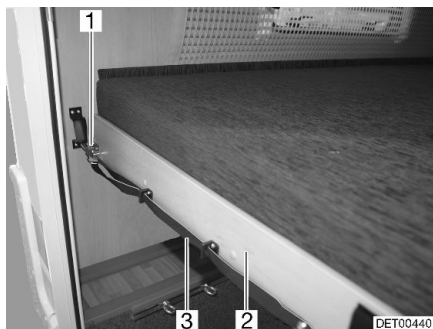


Fig. 52 Bunk bed (rear)

Converting the bunk bed into the rear garage:

- Pull on the loop (Fig. 52,3) and release the latch (Fig. 52,1).
- Pull the slatted frame (Fig. 52,2) together with the mattress forward until it latches in place.

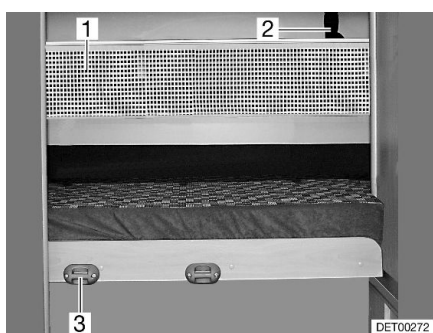


Fig. 53 Safety net

Access ladder Always use the access ladder provided as standard to reach the top bed.

Attaching: ■ Attach the access ladder with the rails to the holder (Fig. 53,3) on the panel.

Safety net The safety net (Fig. 53,1) is stored as standard between the mattress and slatted frame. Do not use the safety net until the person is already in bed.

Setting up: ■ Fasten the retaining straps (Fig. 53,2) to the holders on the ceiling.

7.9.4 Fixed bed (gas-pressure springs)



Fig. 54 Fixed bed

A storage space is underneath the bed. Lift up the slatted frame to place items in the storage space or to empty it from the inside of the vehicle.



- Opening:**
- Lift the mattress forwards.
 - Lift slatted frame. The gas-pressure springs (Fig. 54,1) hold the slatted frame open.
- Closing:**
- Press the slatted frame downwards against the resistance of the gas-pressure springs.

7.9.5 Lying surface of rear single beds

Depending on the equipment, the single beds in the rear may be transformed into a continuous lying surface.

- Pull the width extension out of the console between the beds.
- Insert the supplied additional cushion.

7.10 Converting seating groups for sleeping



- ▷ Depending on the model, the seating group can be different in shape and position to the one shown here.
- ▷ Depending on the model, an enclosed additional cushion must be inserted between the seat cushions.

7.10.1 Central seating group

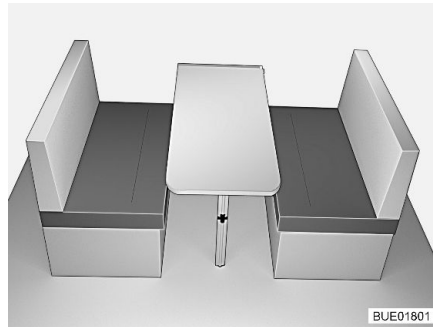


Fig. 55 Prior to conversion

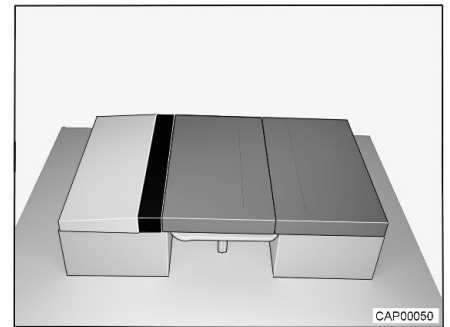


Fig. 56 After conversion

- Convert the table to a bed foundation (see section 7.6.1).
- Remove and put aside one back cushion.
- Place one seat cushion onto the table.
- Place one back cushion flatly on the bench.
- Insert the additional cushion between back cushion and seat cushion.



7.10.2 Front bench seat with divan



- ▷ Do not stand on the bedding box extension when it is pulled out. The bedding box extension may be damaged thereby.

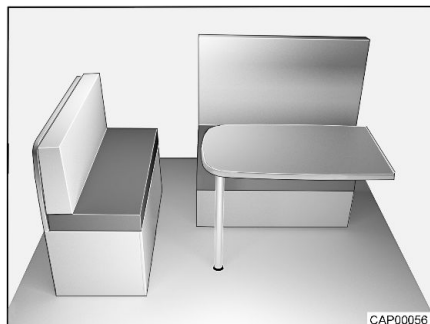


Fig. 57 Prior to conversion

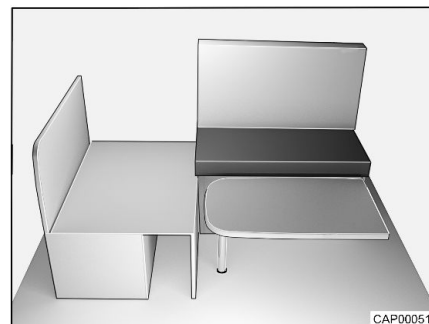


Fig. 58 During conversion

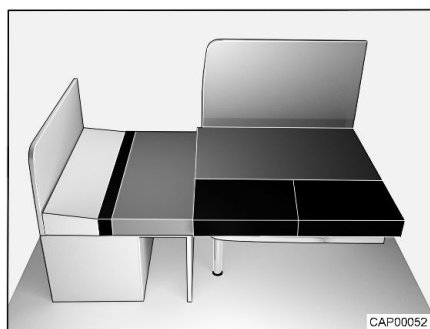


Fig. 59 After conversion

- Depending on the model, insert an additional floor plate at the step to the driver's area to obtain an even seating area.
- Remove the back cushion and the seat cushion of the divan and lay them aside.
- Convert the suspension table into a bed foundation (see section 7.6.1).
- Fold the seat base of the divan upwards.
- Pull up the bedding box extension on the divan.
- Pull out the bedding box extension on the divan all the way.
- Fold down the seat base of the divan.
- Unfold the seat base of the divan.
- Place the seat cushion of the divan on the bedding box extension of the divan.
- Place the back cushion of the divan between the seat cushion and the exterior wall.
- Lay the seat cushion of the front bench seat on the table top.
- Place two short additional cushions in front of the seat cushion.
- Lay the long additional cushion onto the bedding box extension.



7.10.3 Front bench seat with lengthwise seat



- ▷ Do not stand on the bedding box extension when it is pulled out. The bedding box extension may be damaged thereby.

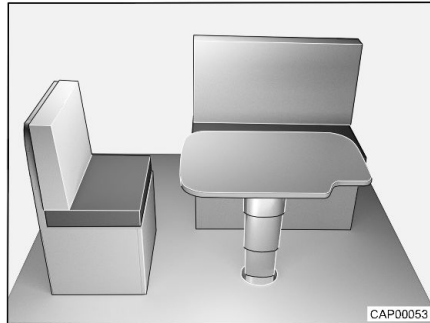


Fig. 60 Prior to conversion

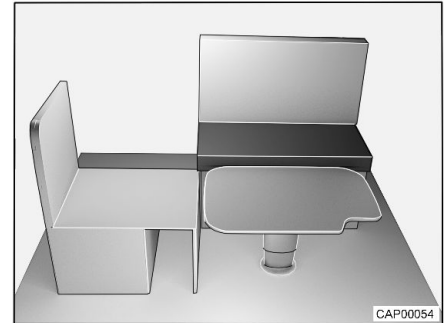


Fig. 61 During conversion

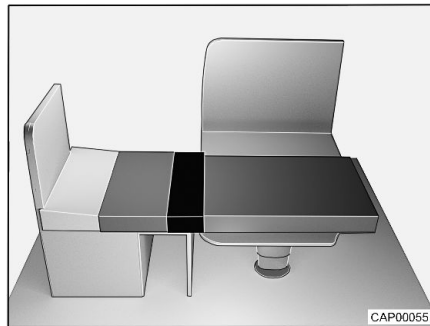


Fig. 62 After conversion

- Model T: Insert additional floor plate on the step to the driver's area to obtain an even seating area.
- Remove the back cushion and the seat cushion of the lengthwise seat and lay them aside.
- Convert the lift-off table to a bed foundation (see section 7.6.2).
- Fold the seat base of the lengthwise seat upwards.
- Lift the bedding box extension on the lengthwise seat slightly.
- Pull out the bedding box extension on the lengthwise seat as far as it will go.
- Fold the seat base of the lengthwise seat down.
- Unfold the seat base of the lengthwise seat.
- Place the seat cushion of the lengthwise seat on the bedding box extension.
- Place the back cushion of the lengthwise seat between the seat cushion and the exterior wall.
- Lay the seat cushion of the front bench seat on the table top.
- Lay the additional cushion onto the bedding box extension.



7.10.4 Front bench seat (guest bed)

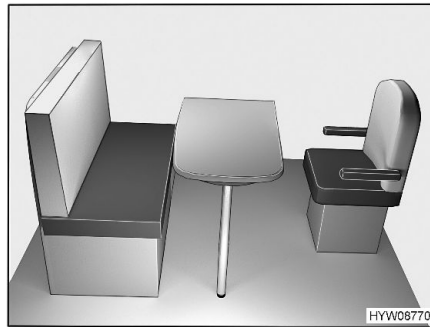


Fig. 63 Prior to conversion

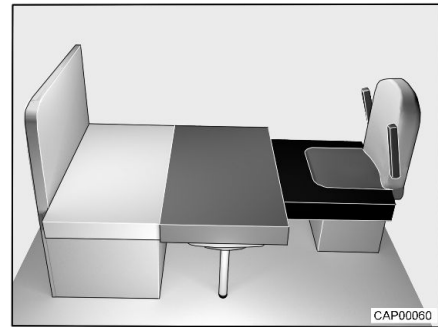


Fig. 64 After conversion

- Turn the driver's seat and push it all the way forward.
- Convert the table to a bed foundation (see section 7.6.1).
- Pull the seat cushion forwards.
- Insert the back cushion between the seat cushion and the rear wall.
- Place the additional cushion on the driver's seat.
- If required, push the driver's seat back to the rear.



Chapter overview

This chapter contains instructions regarding the gas system of the vehicle. The instructions address the following topics:

- safety
- gas consumption
- changing the gas bottles
- gas isolator taps

The operation of the gas operation appliances of the vehicle is described in chapter 10.

8.1 General



- ▶ The operator of the gas system is responsible for the performance of recurring inspections and for complying with the maintenance intervals.
- ▶ Before commencing the journey, when leaving the vehicle or when gas equipment is not in use, close all gas isolator taps and the main isolator tap on the gas bottle.
- ▶ All gas-operated devices (heater, cooker, oven, grill, refrigerator - depending on the equipment) must be switched off for refuelling, on ferries or in the garage. Danger of explosion!
- ▶ Do not use gas-operated devices in closed spaces (e.g. garages). Danger of poisoning and suffocation!
- ▶ Only have the gas system maintained, repaired or altered by an authorised specialist workshop.
- ▶ Have the gas system checked by an authorised specialist workshop according to the national regulations before commissioning. This also applies for not registered vehicles. For modifications to the gas system have the gas system immediately checked by an authorised specialist workshop.
- ▶ The gas pressure regulator, the gas tubes, and the exhaust gas pipes must also be inspected. The gas pressure regulator and the gas tubes must be replaced observing the nationally defined deadlines (the latest after 10 years). The vehicle owner is responsible for seeing that this is carried out.
- ▶ In case of a defect of the gas system (gas odour, high gas consumption) there is danger of explosion! Close regulator tap on the gas bottle immediately. Open doors and windows and ventilate well.
- ▶ If the gas system is defective: Do not smoke; do not ignite any open flames, and do not operate electric switches (light switches etc.). Check the tightness of gas-conducting parts and lines with leakage search spray. Do not check with an open flame.
- ▶ Only the stipulated devices may be connected to internal connections. Do not operate any device outside the vehicle if it is connected to an internal connector.



- ▶ Before using the cooker make sure that there is sufficient ventilation. Open a window or the skylight.
- ▶ Do not use gas-operated cooking and baking facilities for heating purposes.
- ▶ If there are several gas devices, each gas device must have its own gas isolator tap. If individual gas devices are not in use, close the respective gas isolator tap.
- ▶ Ignition safety valves must close within 1 minute after the gas flame has extinguished. A clicking sound is audible. Check function from time to time.
- ▶ The built-in gas devices are exclusively meant for use with propane or butane gas or a mixture of both. The gas pressure regulator as well as all built-in gas devices are designed for a gas pressure of 30 mbar.
- ▶ Propane gas is capable of gasification up to $-42\text{ }^{\circ}\text{C}$, whereas butane gas gasifies at $0\text{ }^{\circ}\text{C}$. Below these temperatures no gas pressure is available. Butane gas is unsuitable for use in winter.
- ▶ Due to its function and construction, the gas bottle compartment is a space which is open to the exterior. Never cover or block up the standard forced ventilations. Otherwise gas that is emitted can not be diverted to the outside.
- ▶ The gas bottle compartment must not be used as storage space.
- ▶ Secure the gas bottle compartment against unauthorised access. To do this, lock the compartment.
- ▶ The regulator tap on the gas bottle must be accessible.
- ▶ Only connect gas-operated devices (e.g. gas grill) which have been designed for a gas pressure of 30 mbar.
- ▶ The exhaust gas pipe must be fitted tightly to the heating system and to the vent and must be sealed. The exhaust gas pipe must not show any evidence of damage.
- ▶ Exhaust fumes must be able to escape into the atmosphere unhindered and fresh air must be able to enter unhindered. For this reason, keep the exhaust pipe and intake openings clean and unobstructed (e.g. free from snow and ice). For this reason, no snow walls or aprons may lie against the vehicle.



8.2 Gas bottles



- ▶ Handle full or emptied gas bottles outside the vehicle only with closed regulator tap and attached protective cap.
- ▶ Gas bottles are only to be transported within the designated gas bottle compartment.
- ▶ Place the gas bottles in vertical position in the gas bottle compartment.
- ▶ Fasten the gas bottles so that they are unable to turn or tilt.
- ▶ Connect the gas tube to the gas bottle without tension.
- ▶ If the gas bottles are not connected to the gas tube, always place the protective cap on top.
- ▶ Close the regulator tap on the gas bottle before the gas pressure regulator or gas tube are removed from the gas bottle.
- ▶ Depending on the connection, unscrew the gas tube from the gas bottle and screw it on the gas bottle again by hand or using a suitable special spanner. The screw connection on the gas bottle generally has a left-hand thread. **Do not** tighten too firmly.
- ▶ Use the gas pressure regulator defroster if the temperature falls below 5 °C.
- ▶ Only use special gas pressure regulators with a safety valve designed for vehicle use. Other gas pressure regulators are not permitted and cannot meet the demanding requirements.
- ▶ Use only 11 kg or 5 kg gas bottles. Camping gas bottles with built-in check valve (blue bottle with max. 2.5 or 3 kg content) are can be used in exceptional cases with a safety valve.
- ▶ Use the shortest possible tube lengths (150 cm max.) for external gas bottles.
- ▶ Never block the floor ventilation openings below the gas bottles.



- ▷ The screw connections on the gas bottles generally have a left-hand thread.
- ▷ For gas-operated units the gas pressure must be reduced to 30 mbar.
- ▷ Connect gas pressure regulator complete with safety valve directly to bottle valve.

The gas pressure regulator reduces the gas pressure in the gas bottle down to the operating pressure of the gas devices.
- ▷ For filling and connecting the gas bottles in Europe the accessories shops have corresponding Euro filling sets and Euro bottle sets.
- ▷ Information available at the dealers or service centre.

The gas pressure regulator reduces the gas pressure in the gas bottle down to the operating pressure of the gas devices.

The gas pressure regulator is permanently installed in the gas bottle compartment. The gas bottle is connected to the gas pressure regulator via a high-pressure gas hose.

The high-pressure gas hoses and their connections are different in the various countries. The accessories shop offers the respective country-specific models and adapters.



8.3 Gas consumption



- ▷ The data about gas consumption of the individual gas devices is standard average values.

Appliances	Gas consumption in grams/hour
Heater	Approx. 170 - 490 g/h
Cooker, per cooker	Approx. 140 - 165 g/h
Refrigerator	Approx. 18 g/h

8.4 Changing gas bottles



- ▶ When changing gas bottles, do not smoke or create any open fire.
- ▶ When you have changed the gas bottle, check whether gas escapes at the connection points and unions. Use a leakage search spray to spray the relevant connection point or union. These agents are available at the accessories shop.

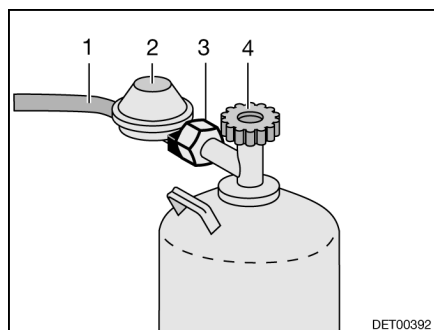
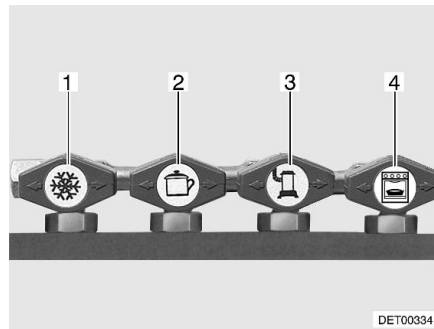


Fig. 65 Gas bottle connection

- Open external gas bottle compartment (see section 7.2).
- If there is a guard plate, fold it down.
- Close the regulator tap (Fig. 65,4) on the gas bottle. Pay attention to the direction of the arrow.
- Unscrew the gas pressure regulator (Fig. 65,2) from the gas bottle at the hexagon nut (Fig. 65,3).
- Remove the gas pressure regulator and the gas tube (Fig. 65,1) from the gas bottle.
- Release the fixing belts and remove the gas bottle.
- Place a filled gas bottle in the gas bottle compartment.
- Fix gas bottle in place with the fixing belts.
- Position the gas pressure regulator (Fig. 65,2) and the gas tube (Fig. 65,1) on the gas bottle and screw in tightly to the gas bottle at the hexagonal nut (Fig. 65,3).
- If there is a guard plate, fold it upwards.
- Close the external flap (see section 7.2).



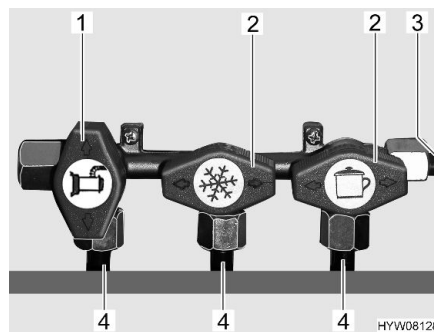
8.5 Gas isolator taps



- 1 Refrigerator
- 2 Cooker
- 3 Heater/boiler
- 4 Oven

Fig. 66 Symbols for the gas isolator taps

A gas isolator tap (Fig. 66) for every gas device is built into the vehicle. The gas isolator taps can be found on the front of the cooker.



- 1 Gas isolator tap open
- 2 Gas isolator tap closed
- 3 Gas pipe
- 4 Pipe to the gas appliance

Fig. 67 Gas isolator taps position (example)

- Opening:**
- Position the gas isolator tap of the corresponding appliance parallel (Fig. 67,1) to the pipe (Fig. 67,4) leading to the gas appliance.
- Closing:**
- Position the gas isolator tap of the corresponding appliance transverse (Fig. 67,2) to the pipe (Fig. 67,4) leading to the gas appliance.





Chapter overview

This chapter contains instructions regarding the electrical system of the vehicle.

The instructions address the following topics:

- safety
- explanations of terms relating to the battery
- 12 V power supply
- living area battery
- loading the batteries
- transformer/rectifier
- panel
- 240 V power supply
- connection to the 240 V power supply
- fuse rating

The operation of the electrical appliances of the housing body is described in chapter 10.

9.1 General safety instructions



- ▶ Only allow qualified personnel to work on the electrical system.
- ▶ All electronic devices (e.g. mobile telephones, radios, televisions or DVD players) which have been retrofitted to the vehicle and are operated during the journey must have certain features: These are the CE certification, the EMC inspection (electromagnetic compatibility) and the "e"-inspection.

Only in this way can the functional reliability of the vehicle be ensured. Otherwise the airbag may be triggered or interference to the on-board electronics may result.



- ▶ During a storm, to protect the electrical devices disconnect the 240 V connection and retract the antennae.

9.2 Terms

Off-load voltage

The off-load voltage is the voltage of the battery in idle condition, i.e. no current is consumed and the battery is not being charged.



- ▶ The battery must remain idle for a while before measuring. After charging the last time, or after the last current has been drained by consumers, wait approximately 2 hours before measuring the idle voltage.

Closed circuit current

Some electrical appliances, such as the clock and the indicator lamps, require continuous electric current, for this reason they are referred to as inactive appliances. This closed circuit current flows even if the device has been switched off.

**Total discharge**

Total discharge of the battery is imminent, if a battery is completely discharged by an active appliance and by closed circuit current and the off-load voltage falls below 12 V.



- ▷ Total discharge damages the battery.

Capacity

Capacity refers to the amount of electricity which can be stored in a battery.

The capacity of a battery is given in ampere hours (Ah). The so-called K20 value is normally used.

The K20 value indicates how much current a battery is able to dispense over a time period of 20 hours without causing damage, or how much current is required to charge a flat battery within 20 hours.

For example, if a battery can dispense 4 amps for 20 hours, then it has a capacity of 4 A x 20 h = 80 Ah.

If more current flows, the capacity of the battery reduces proportionately.

External influences, such as temperature and age may alter the storage capacity of the battery. Capacity details refer to new batteries operating at room temperature.



- ▷ Depending on battery technology, capacity details have a conversion factor of 1.3 to 1.7, which lowers the real capacity by this value.

9.3 12 V power supply

- ▷ To disconnect **all** electrical 12 V appliances from the power supply, disconnect the living area battery from the 12 V power supply. In order to do this, actuate the switch on the transformer/rectifier.

When the vehicle is not connected to the 240 V power supply or the 240 V power supply is switched off, the living area battery supplies the living area with 12 V DC. The living area battery has a limited power supply only. For this reason, electrical appliances such as the refrigerator with 12 V operation or the heater (circulation fan) should not be operated for a long time without using the 240 V power supply.

During heater operation, the circulation fan is switched on and off by a thermostat control. As a result the living area battery is loaded if no 240 V power supply is connected.

In the case of longer lay-ups of the vehicle, all 12 V appliances must be switched off to avoid discharging the living area battery.

Switching off all 12 V appliances:

- Switch off battery cut-off switch on the transformer/rectifier. Thus, the living area battery is fully disconnected from all electrical appliances.

If you leave the vehicle briefly and the refrigerator and/or the heater shall continue working, it suffices to switch off all 12 V appliances not required. Yet nevertheless, observe the charging condition of the living area battery.

Switching off 12 V appliances that are not required:

- Switch off 12 V main switch on the panel. Entrance step and basic light are still supplied with power.



9.3.1 Living area battery



- ▷ Disconnecting and connecting the terminals, as well as changing the living area battery shall only be carried out by qualified personnel. In the event of an incorrect connection, there is the risk of short circuit and fire due to rubbing cables. To reach the living area battery, the seat as well as its turning device must be removed. These components are security related and shall be fitted professionally with screw lock and complying with defined tightening torques.
- ▷ Prior to commencing a journey ensure the living area battery is fully charged. For this reason charge the living area battery for at least 20 hours before commencing the journey.
- ▷ During the trip, use every opportunity to charge the living area battery.
- ▷ After the trip, charge the living area battery fully.
- ▷ Charge the battery for at least 20 hours before laying up.
- ▷ Use the charger module provided on the transformer/rectifier to charge the living area battery. When charging externally, use a regulated charger that is suitable for the battery type and the capacity of the living area battery.
- ▷ For long periods of inactivity (4 weeks or more), either disconnect the living area battery from the 12 V power supply or recharge it regularly.
- ▷ When changing the living area battery, only use batteries of the same type with the same specification as the originally installed battery. Only use a different battery after authorisation by the manufacturer of the vehicle.
- ▷ Before disconnecting or connecting the terminals of the battery, switch off the vehicle engine as well as the 240 V and 12 V power supplies and all appliances. Danger of short circuit!
- ▷ Do not actuate the ignition if the terminals of the battery are disconnected. Danger of short circuit!
- ▷ Take note of the battery manufacturer's users and maintenance instructions.



- ▷ The battery is maintenance-free. Maintenance-free means:
 - It is not necessary to check the acid level.
 - It is not necessary to lubricate the battery poles.
 - It is not necessary to refill the distilled water.Even a maintenance-free battery must be recharged.
Recommendation: perform a full charging cycle every 6 to 8 weeks.
Depending on the battery capacity and the charger, the charging cycle will last 24 to 48 hours.

Position The living area battery is installed in the driver's area below the right-hand seat.



Discharging



The living area battery is discharged by the closed circuit current which some electrical appliances continuously require.

- ▷ Total discharge damages the battery.
- ▷ Recharge battery in good time.

The self-discharge rate of the battery is dependant on temperature. At 20 to 25 °C the self-discharge rate is approx. 3 % of the capacity per month. The self-discharge rate will increase with rising temperatures: At 35 °C the self-discharge rate is approx. 20 % of the capacity per month.

Low temperatures outside reduce the capacity available.

An older battery no longer has the complete capacity available.

The higher the number of active electrical appliances, the faster the energy of the living area battery is consumed.



- ▷ Appliances such as the refrigerator, charger, solar charge regulator, panel, or similar, take power from the battery, even when the 12 V main switch is turned off. Therefore disconnect the living area battery from the 12 V power supply, if the vehicle will not be used for a long period of time.

9.3.2 Charging batteries via a 240 V power supply

If the vehicle is connected to the 240 V power supply, the living area battery and the starter battery are automatically charged by the charger module on the transformer/rectifier. The starter battery is only charged with a float charge. The charging current is adapted to suit the charging condition of the battery. This ensures that it is not possible to overload the battery.

To make use of the maximum output from the charger module on the transformer/rectifier, switch off all electrical appliances during charging.

9.3.3 Charging batteries via the vehicle engine

When the vehicle engine is running, the vehicle alternator recharges the living area battery and the starter battery. When the vehicle engine is switched off, the batteries are automatically disconnected from one another by a relay in the transformer/rectifier. This prevents the starter battery from being run down by electrical appliances in the living area. The starting capability of the vehicle is thus preserved. The charging condition of the living area battery or the starter battery can be read on the panel.

9.3.4 Charging the starter battery



- ▶ The acid in the battery is poisonous and corrosive. Any contact with the skin or the eyes is to be avoided. In the event of contact, rinse immediately with plenty of water (skin, eyes, clothes, objects) and seek medical attention if necessary.
- ▶ In the case of charging with an external charger there is danger of explosion. Sparks can be caused by attaching the battery terminals. Only charge the battery in a well ventilated area and away from naked flames or possible sources of sparks. Batteries can develop and release gases when they are charged.
- ▶ Always remove the starter battery from the vehicle when charging it using an external charger.



- ▷ Do not connect the battery cables to the wrong poles (red cable -> positive pole, black cable -> negative pole).
- ▷ Do not actuate the ignition if the terminals of the battery are disconnected. Danger of short circuit!
- ▷ Before disconnecting or connecting the terminals of the battery, switch off the vehicle engine as well as the 240 V and 12 V power supplies and all appliances. Danger of short circuit!
- ▷ Before charging the battery, check whether the external charger is approved for the battery type.
- ▷ Observe the instruction manuals for the base vehicle and the charger.
- ▷ Irreparable damage to the battery will result if it is overcharged.

Charging with an external charger

When charging the starter battery with an external charger, proceed as follows:

- Turn off the vehicle engine.
- Switch off all electrical appliances.
- Switch off 12 V main switch on the panel. The indicator lamp will go off.
- Switch off battery cut-off switch on the transformer/rectifier.
- Disconnect the mains plug from the transformer/rectifier.
- Switch off all gas appliances, all gas isolator taps and close the regulator tap on the gas bottle.
- There is a danger of short circuit when disconnecting the battery poles. For this reason, first disconnect the negative terminal on the starter battery and then the positive.
- Remove starter battery from the vehicle.
- Check that the external charger is turned off.
- Connect the external charger to the starter battery. Pay attention to the polarity: First connect the positive terminal "+" to the positive pole of the battery, then connect the negative terminal "-" to the negative pole of the battery.
- Switch on the external charger.
- See the instructions for use of the connected charger for information concerning charge period required for the battery.
- See the specifications on the battery for information concerning its strength.
- Disconnect the external charger in reverse order.



9.4 Transformer/rectifier (EBL 119)



- ▷ Do not cover the ventilation slots. Danger of overheating!



- ▷ Depending on the model, not all slots for the fuses are occupied.
- ▷ Deviating from the default assignment, the following fuse values are inserted:
 "Basic light / step": 20 A
 "Reserve 3": 10 A (fuse for USB socket)
- ▷ Further information can be obtained in the manufacturer's instruction manual.

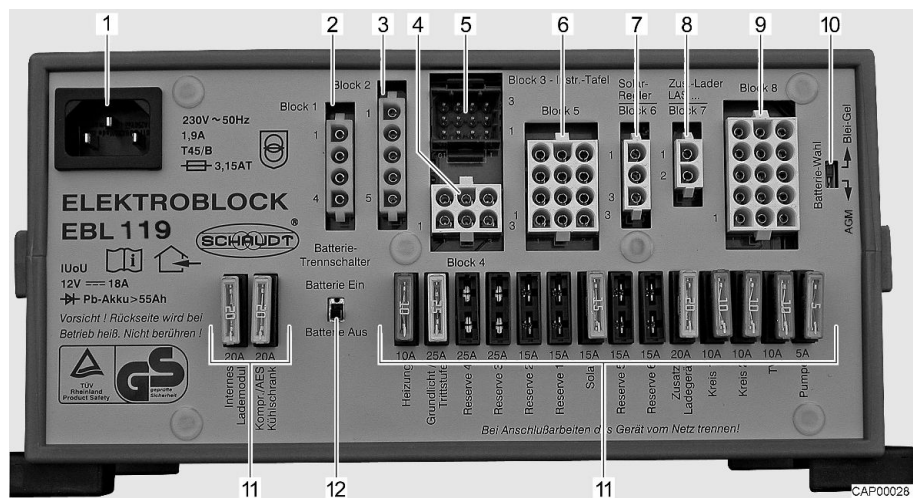


Fig. 68 Transformer/rectifier (EBL 119)

- 1 Main supply socket 240 V~
- 2 Output: Block 1 - refrigerator
- 3 Input: Block 2 - control lines
- 4 Output: Block 4 - heater, safety/drainage valve, basic light (lighting in the entrance area), entrance step
- 5 Output: Block 3 - panel
- 6 Output: Block 5 - solar cell (if fitted), spare 2, spare 3, spare 4
- 7 Output: Block 6 - solar charge regulator (if fitted)
- 8 Output: Block 7 - auxiliary charging unit
- 9 Output: Block 8 - consumer circuit 1, consumer circuit 2, 12 V socket, water pump, spare 1, spare 5, spare 6
- 10 Battery selector switch (lead-gel/AGM)
- 11 Fuses
- 12 Battery cut-off switch ("Batterie Ein/Aus" (battery On/Off))

Functions The transformer/rectifier has the following functions:

- The transformer/rectifier charges the living area battery. The transformer/rectifier charges the starter battery with a float charge only.
- The transformer/rectifier monitors the voltage in the living area battery.
- The transformer/rectifier distributes the current to the 12 V circuits and secures them. Devices with a maximum of 10 A can be connected to the sockets.
- The transformer/rectifier provides connections for a solar charge regulator, an auxiliary charging unit, as well as other control and monitoring functions.



- When the vehicle engine is turned off, the transformer/rectifier separates the starter battery electrically from the living area battery. This prevents the 12 V living area appliances from discharging the starter battery.
- The battery cut-off switch in the transformer/rectifier separates all the appliances from the living area battery.

The transformer/rectifier only works in conjunction with a panel.

When the transformer/rectifier is subject to a heavy load, the fitted charger module reduces the charging current. This protects the charger from overheating. The transformer/rectifier is subject to a heavy load when e.g. an empty living area battery is being charged, additional electrical appliances are turned on and the ambient temperatures are high.

Position The transformer/rectifier is installed in the driver's area below the left-hand seat.

9.4.1 Battery cut-off switch



- ▷ After switching the battery cut-off switch back on again: Put the basic light (lighting in the entrance area), entrance step, heater and spare 4 back into service (depending on the model). To do so, switch on the 12 V main switch briefly. This also applies if the living area battery was disconnected and then reconnected.

The battery cut-off switch disconnects all the living area 12 V appliances. This prevents the living area battery from slowly discharging if the vehicle is not used for a longer period of time (e.g. temporary lay-up).

The batteries can still be charged by the transformer/rectifier when the battery cut-off switch is turned off.

Switching on/off:

- Push the battery cut-off switch upwards: Battery On ("Batterie Ein").
- Push the battery cut-off switch downwards: Battery Off ("Batterie Aus").

9.4.2 Battery selector switch



- ▶ If the battery selector switch is set incorrectly, there is the danger of the formation of detonating (oxy-hydrogen gas). Danger of explosion!



- ▷ Incorrect setting of the battery selector switch damages the living area battery.
- ▷ The factory settings of the battery selector switch must not be changed.
- ▷ Never operate the transformer/rectifier when the battery selector switch has not been set incorrectly.



9.4.3 Battery monitor



- ▷ You must fully recharge a discharged living area battery as soon as possible.

The battery monitor in the transformer/rectifier monitors the voltage in the living area battery.

If the battery voltage falls below 10.5 V, the battery monitor in the transformer/rectifier switches off all the 12 V appliances.

- Measures:*
- Switch off all electrical appliances that are not absolutely essential at the corresponding switch.
 - If necessary, use the 12 V main switch to switch the 12 V power supply back on for a short while. This is only possible, however, when the battery voltage is above 11 V. If the voltage is below this level, the 12 V power supply cannot be switched on again until the living area battery has been recharged.

9.4.4 Charging the battery

When the vehicle engine is running, a relay in the transformer/rectifier alternator switches on the living area battery and the starter battery together and recharges them with the vehicle generator. When the vehicle engine is switched off, the batteries are automatically disconnected from one another again by the transformer/rectifier. This prevents the starter battery from being run down by electrical appliances in the living area. The starting capability of the vehicle is thus preserved. The terminal voltage of the living area battery or the starter battery can be read on the panel.

If the vehicle is connected to the 240 V power supply via the CEE socket outlet, the living area battery and the starter battery are charged by the charger module on the transformer/rectifier. The starter battery is only charged with a float charge. The charging current is adapted to suit the charging condition of the battery. This ensures that it is not possible to overload the battery.

To make use of the maximum output from the charger module on the transformer/rectifier, switch off all electrical appliances during charging.



9.5 Panel (LT 100)

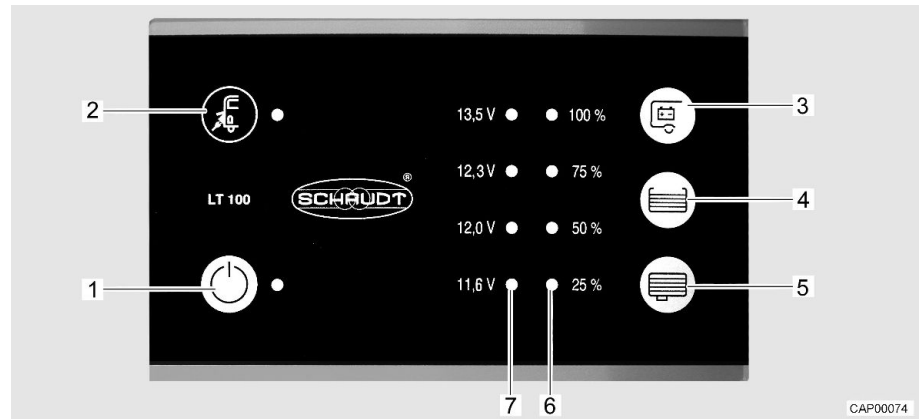



Fig. 69 Panel (LT 100)

- 1 12 V main switch and green LED
- 2 Mains connection symbol and yellow LED
- 3 Button to query the voltage of the living area battery
- 4 Button to query the fill level in the fresh water tank
- 5 Button to query the fill level in the waste water tank
- 6 LED array to display the tank fill level
- 7 LED array to display the battery voltage

The switches and push buttons of the panel are sensor touchpads. The switching function is triggered by touching.

Mains connection


The yellow LED at the mains connection symbol  (Fig. 69,2) is lit when the vehicle is connected to an external mains supply. In this case, the LED will also be lit when the panel is switched off.

9.5.1 12 V main switch


The 12 V main switch (Fig. 69,1) switches the panel and the 12 V power supply of the living area on and off.

Exception: Depending on the model, basic light (lighting in the entrance area), and entrance step remain ready to operate.

Switching on:

- Press switch "" (Fig. 69,1): The 12 V living area power supply is switched on. The LED lights up green.

Switching off:

- Press switch "" (Fig. 69,1) again: The 12 V living area power supply is switched off. The LED goes out.



- ▷ When leaving the vehicle, switch off the main 12 V power supply at the panel. This prevents any unnecessary discharge of the living area battery.
- ▷ Appliances, such as control units (e.g. solar charge regulator, defroster or panel) or fitted appliances (e.g. step) continue to take power from the battery capacity, even if the 12 V power supply on the panel is switched off. Therefore disconnect the living area battery from the 12 V power supply via the switch on the transformer/rectifier if the vehicle will not be used for a long period of time.



9.5.2 LED array for battery voltage

The LED array (Fig. 69,7) displays the battery voltage of the living area battery as follows:

- All LEDs are lit: battery is sufficiently charged.
- Yellow and red LEDs are lit: battery is partly discharged.
- Only red LED is lit: battery is discharged.
- Red LED is flashing: battery is totally discharged.

Displaying the battery voltage:

- Press "☰" button (Fig. 69,3): The battery voltage of the living area battery is displayed.

The following tables will help you correctly interpret the battery voltage of the living area battery displayed on the panel.

Battery voltage (values during operation)	Mobile operation (vehicle moving, no mains connection)	Battery operation (vehicle stationary, no mains connection)	Power operation (vehicle stationary, mains connection)
Below 11.6 V (red LED is flashing)	Battery is totally discharged, no charging via the alternator	Battery is totally discharged	Battery is totally discharged, no charging via the power supply
12 V or less Danger of total discharge (battery alarm) (red LED is lit)	12 V power supply overload	If appliances are switched off: Battery flat	12 V power supply overload
	The battery is not charged by the alternator	If appliances are switched on: Battery overload	The battery is not charged by the transformer/rectifier, the transformer/rectifier is defective
12.3 V to 13.5 V (red, yellow, and green LED are lit)	12 V power supply overload ¹⁾	Normal range	12 V power supply overload ¹⁾
	The battery is not charged by the alternator ¹⁾		The battery is not charged by the transformer/rectifier, the transformer/rectifier is defective ¹⁾
13.5 V (all LEDs are lit)	Battery being charged	Occurs only briefly after charging	Battery being charged

¹⁾ If the voltage does not exceed this range for several hours.



Off-load voltage

Measuring the off-load voltage is a simple method to check the condition of the battery. The off-load voltage is the voltage of the battery in idle condition, when current is neither supplied nor consumed.

The following table helps to correctly interpret the displayed battery off-load voltage. The specified values are guide values for dryfill batteries.

LT 100 indicator	Off-load voltage values	Battery charge
Red LED flashes	11.6 V or less	Battery is fully discharged
Red and yellow LED are lit	11.6 V to 12.0 V	Battery is discharged to totally discharged
Red and yellow LED are lit	12 V to 12.3 V	Battery is empty or charged up to approx. 50 %
Red, yellow, and lower green LED are lit	12.3 V to 13.5 V	Battery is charged from approx. 50 % to fully charged
All LEDs light up	Over 13.5 V	(Only appears while charging)



▷ Total discharge causes irreparable damage to the battery.

Measures:

- When the battery alarm comes on, switch off the appliances and charge the living area battery, either by mobile operation or by connection to a 240 V power supply.

9.5.3 LED array for tank fill level

The LED array (Fig. 69,6) displays the fill level of the fresh water tank or of the waste water tank.

Display fill level:

- Press "☰" button (Fig. 69,4): The fill level of the fresh water tank is displayed by lit LEDs.
- Press "☷" button (Fig. 69,5): The fill level of the waste water tank is displayed by lit LEDs.

Level indicator

LED indicator	Tank fill level
All LEDs light up	Full tank
3 LEDs light up	Tank approx. 3/4 full
2 LEDs light up	Tank approx. 1/2 full
1 LED lights up	Tank approx. 1/4 full
Bottom LED flashes	Tank empty



▷ Further information can be obtained in the manufacturer's instruction manual.



9.6 240 V power supply



- ▶ Only allow qualified personnel to work on the electrical system.
- ▶ Have the vehicle's electrical system checked by a qualified electrician at least once every 3 years. If the vehicle is used frequently, an annual check is recommended.

The 240 V power supply provides electricity for:

- sockets with earth contact for appliances with maximum 16 A
- refrigerator
- transformer/rectifier

The electrical appliances connected to the 12 V power supply of the living area are supplied with voltage by the living area battery.

Connect the vehicle to an external 240 V power supply system as often as possible. The charger module in the transformer/rectifier automatically charges the living area battery. In addition to this, the starter battery is charged with a float charge.

9.6.1 240 V connection (CEE socket outlet)



- ▷ Overvoltage can damage connected devices. Overvoltage can be caused by lightning, irregular voltage sources (e.g. petrol-operated generators) or power connections on ferries for example.

Requirements concerning the 240 V connection

- The connecting cable, the plug connectors at the point of supply and the plug connector to the vehicle must comply with IEC 60309. The standard designation for the plug connectors is "CEE blue".
- Use H07RN-F rubber sheathed cable with a minimum cable cross-section of 2.5 mm² and a maximum length of 25 m.
- Earth contact connectors (safety) are not permitted. The interconnection of CEE/safety adapters is also prohibited.

9.6.2 Connecting the 240 V power supply



- ▶ The external 240 V power supply must be protected by fuse with a fault current protection switch (FI-switch, 30 mA).
- ▶ To prevent overheating, the cable must be fully uncoiled from the cable reel.
- ▶ In case of doubt or if the 240 V supply is not available or is faulty, contact the operator of the power supply device.



- ▷ The 240 V connection in the vehicle is equipped with a fault current protection switch (FI-switch).
- ▷ The dimensions, the number of safety cut-outs, and the triggering value of the safety cut-outs of the fuse box may differ from the shown type. The version of the fuse box depends on the model, the equipment and the country in which the vehicle is put into circulation.

The vehicle can be connected to an external 240 V power supply.

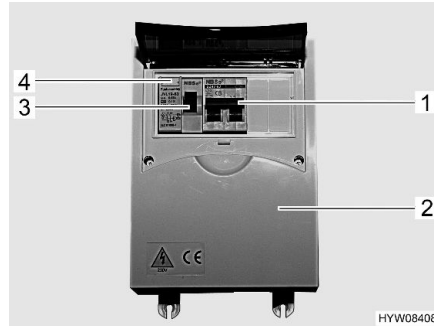


Fig. 70 240 V fuse box with safety cut-out and FI-switch

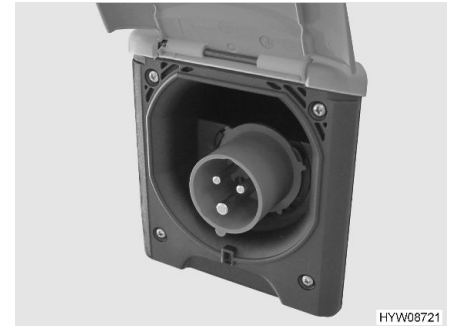


Fig. 71 240 V connection on the vehicle (CEE socket outlet)

Connecting the vehicle:

- Check whether the power supply device is suitable regarding connection, voltage, frequency and current.
- Check whether the cables and connections are suitable.
- Check the plug connectors and cables for visible damage.
- Switch off the safety cut-out (Fig. 70,1) in the fuse box (Fig. 70,2).
- Open the cover of the 240 V connection on the vehicle (Fig. 71) and insert the plug connector. Ensure that the detent of the spring-mounted pivoting cover is engaged in position.
- Plug the connector of the connecting cable into the socket of the power supply device. Ensure that the detent of the spring-mounted pivoting cover is engaged in position.
- Switch on the safety cut-out in the fuse box.

Checking the fault current protection switch:

- When the vehicle is connected to the 240 V supply, press the test button (Fig. 70,4) of the fault current protection switch (FI-switch) (Fig. 70,3) in the fuse box (Fig. 70,2). The fault current protection switch must trip.
- Switch the fault current protection switch back on again.

Unplugging the connection:

- Switch off the safety cut-out (Fig. 70,1) in the fuse box (Fig. 70,2).
- Loosen the detent on the power supply device and unplug the connection cable from the socket.
- Loosen the detent on the vehicle, unplug the plug connector and close the cover of the 240 V connection.



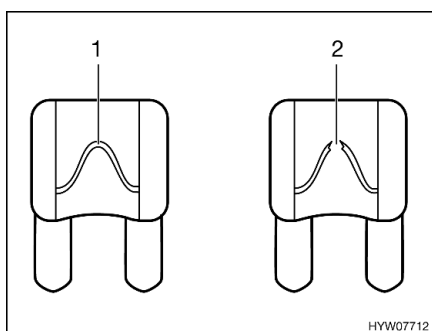
9.7 Fuses



- ▶ Only replace defective fuses when the cause of the defect is known and has been remedied.
- ▶ Replace defective fuses only after the power supply has been turned off.
- ▶ Never bridge or repair fuses.
- ▶ Only replace faulty fuses with a new fuse with the same rating.

9.7.1 12 V fuses

The appliances connected to the 12 V power supply in the living area are fused individually. The fuses are accessible at different positions in the vehicle.



- 1 Unbroken fuse element
- 2 Broken fuse element

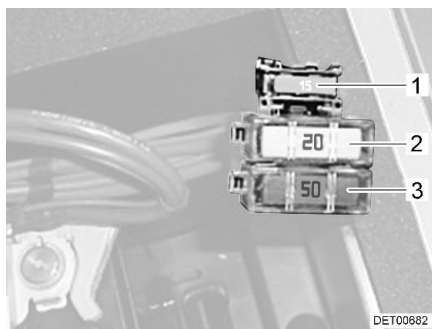
Fig. 72 12 V fuse

An intact 12 V fuse can be detected by the unbroken fuse element (Fig. 72,1). If the fuse element is broken (Fig. 72,2), change the fuse.

Before changing fuses, take the function, value and colour of the relevant fuses from the following specifications. When changing fuses, only use flat fuses with the values shown below.

Fuses on the starter battery

The fuses are installed in the vicinity of the starter battery. The starter battery is on the floor between the seats in the driver's cabin and can be accessed under a cover.



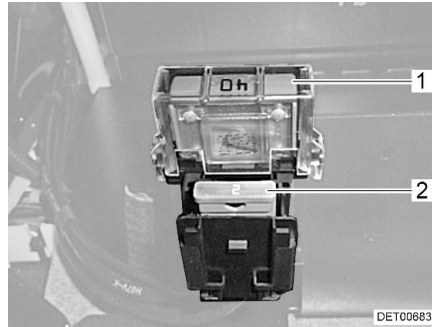
- 1 Flat fuse 15 A/blue
(Control for relay)
- 2 Jumbo flat fuse 20 A/yellow
(Back-up fuse for refrigerator)
- 3 Jumbo flat fuse 50 A/red
(Fuse protection for starter battery)

Fig. 73 Fuses on the starter battery



Fuses on the living area battery

The fuses are installed in the console of the right-hand seat in the driver's area.

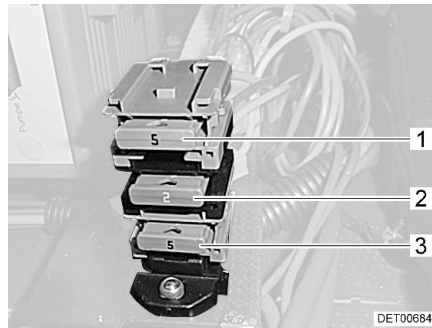


- 1 Jumbo flat fuse 40 A/orange (Fuse protection for living area battery)
- 2 Flat fuse 2 A/grey (Control 12 V/control unit)

Fig. 74 Fuses on the living area battery

Fuses next to the transformer/rectifier

The fuses are installed in the console of the left-hand seat in the driver's area.



- 1 Flat fuse 5 A/beige (Side marking lights)
- 2 Flat fuse 2 A/grey (Control D+)
- 3 Flat fuse 5 A/beige (Side marking lights)

Fig. 75 Fuses next to the transformer/rectifier

Fuse for the Thetford toilet

The toilet has a maintenance-free fuse which resets automatically.



9.7.2 240 V fuse



- ▷ Check the fault current protection switch for each connection to the 240 V power supply, at least once every 6 months.



- ▷ The dimensions, the number of safety cut-outs, and the triggering value of the safety cut-outs of the fuse box may differ from the shown type. The version of the fuse box depends on the model, the equipment and the country in which the vehicle is put into circulation.



Fig. 76 240 V fuse box with safety cut-out and FI-switch

A fault current protection switch (FI-switch) in the fuse box protects the complete vehicle from fault current (0.03 A). A downstream safety cut-out (10 A) (Fig. 76,2) secures the 240 V power supply.

Checking the fault current protection switch:

- When the vehicle is connected to the 240 V power supply, press the test button (Fig. 76,1). The fault current protection switch must trip.

Position

Depending on the model and level of equipment, the 240 V fuse can be fitted in the following places:

- In the wardrobe
- In the lower cupboard of the kitchen
- In the seat box of the lengthwise seat



Chapter overview

This chapter contains instructions regarding the appliances of the vehicle.

The instructions refer exclusively to the operation of the appliances.


Further information about the appliances can be found in the instruction manuals for the appliances, included separately with the vehicle.

The instructions address the following topics:

- heater (with boiler function)
- gas cooker
- gas oven
- extractor hood
- refrigerator

10.1 General

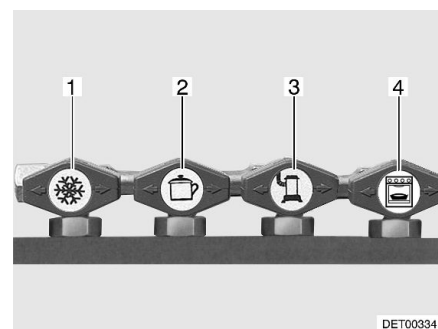


- ▷ The heat exchanger of the Truma hot-air heater has to be replaced after 30 years. Only the manufacturer of the heater or an authorised specialist workshop is allowed to replace the heat exchanger. The operator of the heater must see to it that the parts are replaced.
 - ▷ For safety reasons, spare parts for pieces of heating appliances must correspond with manufacturer's instructions and be permitted by the manufacturer as a spare part. These spare parts may only be fitted by the manufacturer or an authorised specialist workshop.
-  Further information can be obtained in the instruction manual for the respective appliance.

The heater/boiler, cooker and refrigerator are fitted depending on the model of the vehicle.

In this instruction manual a description is given only for the operation of the appliances and their particular features.

To operate gas appliances, first open the regulator tap on the gas bottle and the gas isolator tap corresponding to the appliance.



- 1 Refrigerator
- 2 Cooker
- 3 Heater/boiler
- 4 Oven

Fig. 77 Symbols for the gas isolator taps



10.2 Heater / production of hot water

The heater can both heat up the vehicle interior (heating the room air) and heat up the domestic water (boiler function). The following instructions are also valid if the heater is only used as boiler.



- ▶ Never let gas escape unburned due to danger of explosion.
- ▶ Never run the heater in gas operation when refuelling, on ferries or in the garage. Danger of explosion!
- ▶ Never operate the heater in gas operation in closed spaces (e.g. garages). Danger of poisoning and suffocation!
- ▶ Do not use the space above and behind the heater as a storage space.
- ▶ The domestic water can be heated up to 65 °C. Risk of scalding!



- ▷ The circulation fan is automatically switched on when the hot-air heater is activated, and it stays on. This puts an immense strain on the living area battery, if the vehicle is not connected to an external 240 V power supply. Take into consideration that the living area battery only has limited reserves of energy.
- ▷ Never use the production of hot water without water inside it.
- ▷ When the production of hot water of the heater is not used, empty the domestic water container if there is a risk of frost.
- ▷ Only operate the production of hot water with the maximum temperature setting if you require a large quantity of warm water. This protects the appliance against the build-up of limescale.



- ▷ Do not use the water heated by the heater as drinking water.
- ▷ Operate the heater a few minutes under full load at regular intervals (at least every 3 months) to remove condensation. This prevents odours.

Initial start-up

When lighting the heater for the first time a small amount of smoke and odour will occur. Immediately set the operating switch of the heater to its highest position. Open doors and windows and ventilate well. Smoke and odour will disappear by themselves after a while.

10.2.1 Models with waste gas vent on the right-hand side of the vehicle



- ▶ If the awning is put up and the heater is running in gas operation, exhaust gases from the heater can escape into the awning area. Danger of suffocation! Make sure the area is sufficiently ventilated.



10.2.2 Safety switch

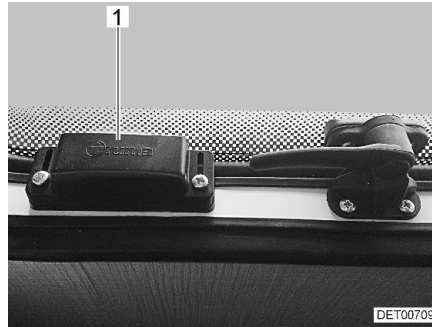


Fig. 78 Safety switch

In vehicles where the waste gas vent for the heater is positioned underneath a hinged window, there is a danger that exhaust gases could get into the vehicle if the hinged window is open. For this reason these vehicles have a safety switch (Fig. 78,1) fitted on the hinged window.

If the hinged window is opened while the heater is in operation, automatic shutoff stops the operation of the heater. This also applies if the hinged window is opened in the "continuous ventilation" position.

If the heater was in operation when the hinged window was opened, it will automatically restart when the hinged window is closed.

10.2.3 To heat properly

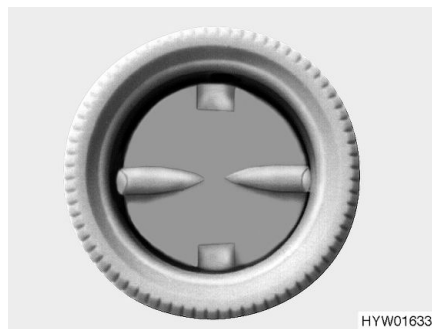


Fig. 79 Air outlet nozzle

Hot air distribution

Several air outlet nozzles (Fig. 79) are built into the vehicle. Pipes conduct the warm air to the air outlet nozzles. Turn the air outlet nozzles in a suitable position so the air can escape as required. To avoid draft close the air outlet nozzles on the dashboard and set the air distribution of the base vehicle to air circulation.

Adjusting the air outlet nozzles

- Fully open: Full hot air stream
- Half or partially open: Reduced hot air stream

When five air outlet nozzles are completely opened, less warm air escapes through each nozzle. However, if only three air outlet nozzles are opened, more warm air flows out of each nozzle.



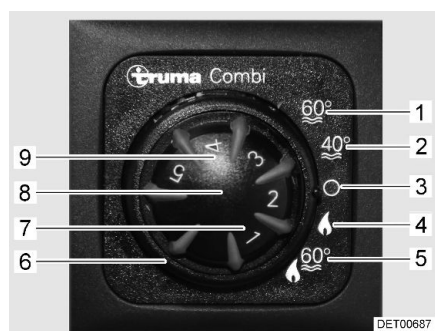
10.2.4 Heater and production of hot water (Truma Combi)



- ▷ If the heater is not in operation when there is a risk of frost, empty the domestic water container.

The power supply of the heating control system cannot be interrupted by means of the 12 V main switch.

The heater is operated with gas.



- 1 Summer operation water temperature 60 °C
- 2 Summer operation water temperature 40 °C
- 3 Off
- 4 Winter operation "Only heater"
- 5 Winter operation "Heater and production of hot water"
- 6 Rotary switch (external ring)
- 7 Indicator lamp "Heater operation" (green)
- 8 Temperature control knob
- 9 Indicator lamp "Heating up period of production of hot water" (yellow)/ "Fault" (red)

Fig. 80 Operating unit

Operating modes

The heater can be operated in different operating modes:

- Winter operation (with or without production of hot water)
- Summer operation (only production of hot water)

Selecting operating mode:

- Set the operating mode using the rotary switch (Fig. 80,6).

Winter operation

In winter operation "Heater and production of hot water" (Fig. 80,5) the domestic water is automatically heated up when the heater is switched on. If the heater switches off after the required room temperature has been reached, the domestic water will continue to heat up until the set water temperature has been reached.

A temperature sensor next to the panel measures the room temperature.

In the operating mode "Only heater" (Fig. 80,4) the heater can be operated with an empty domestic water container.

Switching on:

- Open the regulator tap on the gas bottle and the gas isolator tap "Heater/boiler".
- Turn the temperature control knob (Fig. 80,8) on the operating unit to the desired heating level.
- Set rotary switch (Fig. 80,6) to winter operation "Only heater" (Fig. 80,4) or to winter operation "Heater and production of hot water" (Fig. 80,5).

The green indicator lamp (Fig. 80,7) is on.

The circulation fan automatically switches on when the heater is activated.

Switching off:

- Turn the rotary switch (Fig. 80,6) to "O" (Fig. 80,3).
- Close the gas isolator tap "Heater/boiler" and the regulator tap on the gas bottle.

After switching off the heater, the circulation fan may still run for a moment to use up the residual heat.

**Summer operation**

It is not possible to heat the vehicle in "Summer" operating mode. In this operating mode, only the domestic water is heated up to either 40 °C or 60 °C.

Switching production of hot water on:

- Open the regulator tap on the gas bottle and the gas isolator tap "Heater/boiler".
- Set the rotary switch (Fig. 80,6) on the operating unit (Fig. 80) to "Summer operation" (Fig. 80,1 or 2).

The yellow indicator lamp (Fig. 80,9) is illuminated during the heating up period. When the set water temperature is reached, the period of heating up is finished and the yellow indicator lamp fades.

In case of fault, the indicator lamp (Fig. 80,9) on the operating unit glows red (see section 15.7).

Switching production of hot water off:

- Set the rotary switch (Fig. 80,6) on the operating unit (Fig. 80) to "O".
- Close the gas isolator tap "Heater/boiler" and the regulator tap on the gas bottle.

10.2.5 Hot-air heater and boiler with CP plus digital operating unit

- ▷ If there is a risk of frost and the heater is not in operation, empty the boiler.
- ▷ The circulation fan is automatically switched on when the hot-air heater is activated, and it stays on. This puts an immense strain on the living area battery, if the vehicle is not connected to an external 240 V power supply. Take into consideration that the living area battery only has limited reserves of energy.



- ▷ The hot-air heater can even run on an empty boiler.
- ▷ If the power supply to the heater was interrupted, the time must be reset.

Operating unit

The operating unit is divided into two sections:

- Display
- Operating buttons



- 1 Display
- 2 Rotary push button
- 3 Back button

Fig. 81 Operating unit (hot-air heater and boiler)

After being switched on, the most recently set values/operating parameters are activated.

If no button is pressed, the operating unit switches to stand-by mode after a few minutes.

If the time is set, the display in stand-by mode alternates between the time and the room temperature set.

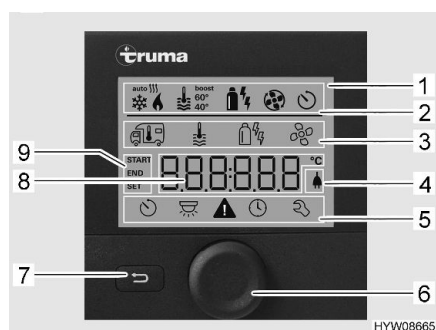


After being switched off, the display in the control unit may remain active for several minutes since the heater is still running.

Operating buttons

The operating buttons have the following functions:

Button	Button operation	Function
Rotary push button (Fig. 81,2)	Turn to the right	Menu is run through from left to right Values are increased
	Turn to the left	Menu is run through from right to left Values are decreased
	Press briefly	Selected value is saved Menu item is selected for changing values (selected menu item flashes)
	Press (3 seconds)	Switch on or switch off
Back button (Fig. 81,3)	Press	Return from a menu item without saving values



- 1 Display
- 2 Status line
- 3 Upper menu line
- 4 Display line voltage 240 V
- 5 Lower menu line
- 6 Rotary push button
- 7 Back button
- 8 Settings and values display area
- 9 Timer display

Fig. 82 Operating unit with displays

Display

The display is divided into four sections:

- Status line (Fig. 82,2)
- Upper menu line (Fig. 82,3)
- Display area (Fig. 82,8)
- Lower menu line (Fig. 82,5)

Switching operating unit on/off:

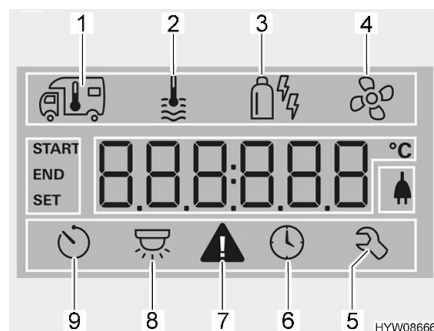
- Press and hold the rotary push button (Fig. 82,6) for approx. 3 seconds. Both menu lines (Fig. 82,3 and Fig. 82,5) are displayed. The first symbol flashes.



- ▷ Switching the operating mode on/off means switching between stand-by and setting mode. In stand-by mode, the display alternates between the room temperature and the time that have been set.

Carrying out settings:

- Turn rotary push button (Fig. 82,6) until the required menu symbol flashes.
- Press rotary push button.
- Turn rotary push button until the required value is displayed.
- Press rotary push button to save the value set. If you do not wish to change the value originally set: Press back button (Fig. 82,7).



- 1 Heater
- 2 Hot water
- 3 Operating mode
- 4 Fan
- 5 Service menu
- 6 Setting the time
- 7 Warning symbol
- 8 Lighting (not used here)
- 9 Timer

Fig. 83 Display (operating unit)

Switching on the heater:

- Open the regulator tap on the gas bottle and the gas isolator tap "Heater/boiler".
- Turn rotary push button (Fig. 82,6) until the heater menu symbol (Fig. 83,1) flashes.
- Press rotary push button.
- Turn rotary push button until required value is displayed.
- Press rotary push button to save the value set. The symbol in the status line (Fig. 82,2) flashes until the room temperature set is reached. If you do not wish to change the value originally set: Press back button (Fig. 82,7).

Switching off the heater:

- Turn temperature value back until OFF is displayed. Press rotary push button to save.
- ▷ The required room temperature can also be changed in stand-by mode by turning the rotary push button.



Switching on hot water production:






- Open the regulator tap on the gas bottle and the gas isolator tap "Heater/boiler".
- Turn rotary push button (Fig. 82,6) until the hot water menu symbol (Fig. 83,2) flashes.
- Press rotary push button.
- Turn rotary push button until the required value is displayed:
 - OFF: Hot water production is switched off.
 - 40°: Hot water is heated to 40 °C.
 - 60°: Hot water is heated to 60 °C.
 - BOOST: Fast heating of hot water (boiler priority) for max. 40 minutes. The water temperature is then held at a higher level for two reheating cycles (approximately 62 °C).
- Press rotary push button to save the value set. The symbol in the status line (Fig. 82,2) flashes until the hot water temperature set is reached. If you do not wish to change the value originally set: Press back button (Fig. 82,7).

Switching off hot water production:

- Turn rotary push button until OFF is displayed. Press rotary push button to save.



Operating modes The hot-water heater with the boiler can be operated with various energy sources.

- Selecting operating mode:*
- Turn rotary push button (Fig. 82,6) until the menu symbol operating mode (Fig. 83,3) flashes.
 - Press rotary push button.
 - Turn rotary push button until the desired operating mode is displayed:
 -  Gas operation
 -  Electrical operation (900 W)
 -  Electrical operation (1800 W)
 -  Gas and electrical operation (900 W)
 -  Gas and electrical operation (1800 W)
 - Press the rotary push button to save the set operating mode. To revert to the original setting: Press back button (Fig. 82,7).



- ▷ 240 V electrical operation is only possible when the vehicle is connected to the 240 V power supply.
- ▷ Select the output level for 240 V electrical operation so that it corresponds to the fuse protection of the 240 V connection (900 W for 3.9 A fuse, 1800 W for 7.8 A fuse).

The combination of gas operation and 240 V electrical operation shortens the time required to heat up the vehicle.

- Setting the fan:*
- Turn rotary push button (Fig. 82,6) until the fan menu symbol (Fig. 83,4) flashes.
 - Press rotary push button.
 - Turn rotary push button until the required value is displayed:
 - OFF: Fan is switched off.
 - VENT: Air circulation
 - ECO: Low fan setting
 - HIGH: High fan setting
 - BOOST: Fast room heating. Boost is available if the current room temperature is at least 10 °C below the selected room temperature.
 - Press rotary push button to save the value set. If you do not wish to change the value originally set: Press back button (Fig. 82,7).

- Setting the timer:*
- Turn rotary push button (Fig. 82,6) until the timer menu symbol (Fig. 83,9) flashes.
 - Press rotary push button. The start time is displayed and the hour display flashes.
 - Turn rotary push button until the hour of the selected start time is displayed.
 - Press rotary push button. The minute display flashes.
 - Turn rotary push button until the minute of the selected start time is displayed.
 - Press rotary push button.
 - Proceed in the same way to set the switch-off time, the required room temperature, the hot water setting and the fan setting.
 - Press rotary push button. The timer is activated. The timer symbol (Fig. 83,9) flashes when the timer is programmed and active.



- ▷ The service menu contains items that generally only need to be set once (language, background brightness, calibration), as well as information for service centres (version numbers).

Fault display

The warning symbol (Fig. 83,7) flashes in the event of a warning. The heater continues to operate. In the event of only a temporary fault, the warning symbol goes out automatically.

In the event of a warning, the control unit displays the error code for the fault. The heater is switched off. Press rotary push button to restart the heater.



- ▷ Further information can be obtained in the manufacturer's instruction manual.

10.2.6 Safety/drainage valve

The heater is equipped with a safety/drainage valve (Fig. 84). The safety/drainage valve prevents water for the production of hot water from freezing, when there is frost and the heater is not switched on.



- ▷ When the vehicle is not used for a long period of time, open the safety/drainage valve and empty the heater.
- ▷ At temperatures below 2 °C the safety/drainage valve opens automatically. Only if the temperature of the safety/drainage valve lies above 6 °C can it be shut again.
- ▷ The water pump and the water fittings are not protected against freezing by the safety/drainage valve.



- ▷ The drainage neck of the safety/drainage valve has to be free of dirt (e.g. leaves, ice) at all times.

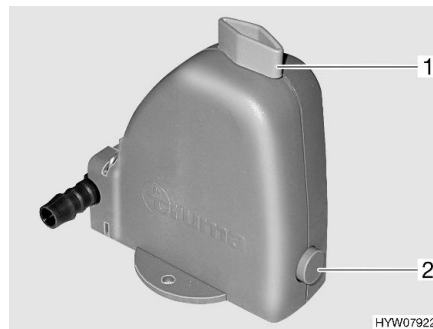


Fig. 84 Safety/drainage valve

Position

See section 11.2.7.

Filling/emptying domestic water container

The domestic water container can be supplied with water from the water tank.

Filling the domestic water container with water:

- Switch on the 12 V power supply on the panel.
- Close the safety/drainage valve. Turn the knob (Fig. 84,1) perpendicular to the safety/drainage valve and push the push button (Fig. 84,2) in.
- Set all the water taps to "Hot" and open them. The water pump is turned on. The warm water pipes are filled with water.



Emptying the domestic water container:

- Keep the water taps open until the water flowing out of the water taps has no bubbles in it. This is the only way to ensure that the domestic water container is full of water.
 - Close all water taps.
 - Set the rotary switch (Fig. 80,6) on the operating unit (Fig. 80) to "O".
 - Open the safety/drainage valve. To do this turn the knob (Fig. 84,1) parallel to the safety/drainage valve. The push button (Fig. 84,2) jumps out. The domestic water container is emptied to the outside through the safety/drainage valve.
 - Check whether the water has been drained completely from the domestic water container (approx. 12 litres).
- ▷ Further information can be obtained in the manufacturer's instruction manual.



10.2.7 Wall flue

Fresh air and exhaust gases of the heater system are conducted in a two-chamber wall flue.



- ▷ Park the vehicle such that the wall flue gets enough fresh air.
- ▷ The wall flue must be free at all times. Do not cover the wall flue.
- ▷ When camping in winter, maintain wall flue free of snow and ice.
- ▷ Check the wall flue periodically depending on the weather (snow, leaf fall, dirt, etc.). If necessary, clean the wall flue.
- ▷ When washing the vehicle do not aim the water jet directly at the wall flue.
- ▷ When disregarding this, the flawless operation of the heater can not be guaranteed.



Fig. 85 Wall flue (hot-air heater)

The wall flue is mounted on the left side wall.



10.2.8 Electrical floor warming unit



- ▶ On models with electrical floor warming unit, never drill holes in the floor or screw in any screws. Careful with sharp objects. There is danger of a power cut or a short circuit due to damage to a heater wire.



- ▷ Do not cover the regulator. Danger of overheating!



- ▷ The electrical floor warming unit only operates if the vehicle is connected to the 240 V power supply.
- ▷ The output of the electrical floor warming unit alone is not sufficient to heat the living area.

The regulator for the electrical floor warming unit is located in the wardrobe.

Operating levels

The electrical floor warming unit has four operating levels:

- 0 "Off"
- 20 V "Low heating level"
- 22 V "Medium heating level"
- 24 V "High heating level"



Fig. 86 Regulator for electrical floor warming unit

Switching on:

- Connect the vehicle to the 240 V power supply (see section 9.6.1).
- Turn the control knob (Fig. 86,2) to the required heating level.

Switching off:

- Turn control knob (Fig. 86,2) to "0" position.

After switching off, the floor remains warm for a while, due to residual heat. If the regulator is overloaded, the overload protection is actuated. The pin (Fig. 86,1) jumps out.

Switching on overload protection:

- Press the pin (Fig. 86,1) on the overload protection when the regulator is cooled.



10.3 Cooker



- ▶ During operation of the gas cooker, do not leave the gas cooker unattended. Even if the gas cooker cannot be overseen for only a short time (e.g. Visit to the toilet), switch the gas cooker off.
- ▶ Never let gas escape unburned due to danger of explosion.
- ▶ Before using the cooker make sure that there is sufficient ventilation. Open windows or the skylight.
- ▶ Do not use gas cooker or gas oven for heating.
- ▶ Always protect your hands with cooking gloves or potholders when handling hot pots, pans and similar items. There is a risk of injury!

10.3.1 Gas cooker



- ▶ During activation and operation of the gas cooker, no flammable objects or highly inflammable objects such as dishcloths, napkins etc. must be near the gas cooker. Fire hazard!
- ▶ The process of ignition must be visible from above and must not be covered by cooking pans placed on the cooker.
- ▶ If there is a flame protection, always put it up when using the gas cooker.
- ▶ The gas cooker lid is held closed by a spring. When closing there is danger of getting injured!



- ▷ Do not use the glass gas cooker cover as a hob.
- ▷ Do not close the gas cooker lid while the gas cooker is in operation.
- ▷ Do not apply pressure on the gas cooker lid when it is closed.
- ▷ Do not place hot cooking pans on the gas cooker lid.
- ▷ Keep the gas cooker lid open after cooking until the burners are cool. Otherwise the glass plate could shatter.



- ▷ Only use pots and pans whose diameter is appropriate for the gas cooker burners.
- ▷ When the flame goes out, the thermocouple automatically cuts the gas supply.
- ▷ Further information can be obtained in the manufacturer's instruction manual.

The vehicle kitchen unit is fitted with a three-burner gas cooker.



Fig. 87 Operating controls for gas cooker

- Switching on:**
- Open the regulator tap on the gas bottle and the gas isolator tap "Cooker".
 - Open the gas cooker lid.
 - Depending on the model, fold out or set up the flame protection.
 - Turn the control knob (Fig. 87,1) on the burner you wish to use to the ignition position (large flame).
 - Press the control knob down and hold it.
 - Light the burner with a gas lighter, a match or other suitable means of lighting.
 - Once the flame is burning, the control knob must be held down for 10 to 15 seconds, until the thermocouple automatically keeps the gas supply open.
 - Release the control knob and turn to the desired setting.
 - If ignition is unsuccessful, repeat the entire procedure.
- Switching off:**
- Turn the control knob to the 0-position. The flame fades.
 - Close the gas isolator tap "Cooker" and the regulator tap on the gas bottle.

10.3.2 Gas oven with grill (Thetford Duplex)



- ▶ Keep the ventilation openings on the gas oven open at all times.
- ▶ There must be no flammable or highly inflammable objects such as dishcloths, clothes, etc. near the gas oven when the oven/grill is being lit and during operation. Fire hazard!
- ▶ When lighting the grill and when grilling, the door of the gas grill must always remain open.
- ▶ If ignition has not taken place, repeat the entire procedure. If necessary, check if there is gas and/or current in the gas oven.
- ▶ If the gas oven/grill still does not work, close the gas isolator tap and notify your service centre.
- ▶ If the burner flame is accidentally extinguished, turn the control knob to the "0" position and leave the burner off for at least 1 minute. Then ignite it again.
- ▶ When grilling, pull out the heat guard and leave the flap fully open.



- ▷ Before using the gas oven for the first time run it for 30 minutes at maximum temperature without any contents.
- ▷ When the flame goes out, the thermocouple automatically cuts the gas supply.
- ▷ Further information can be obtained in the manufacturer's instruction manual.

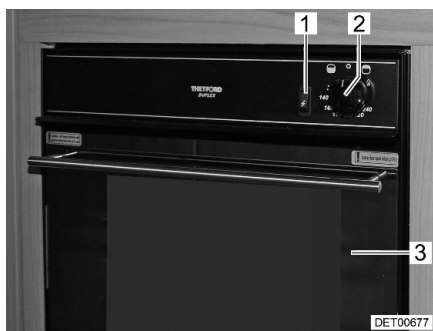


Fig. 88 Gas oven with grill

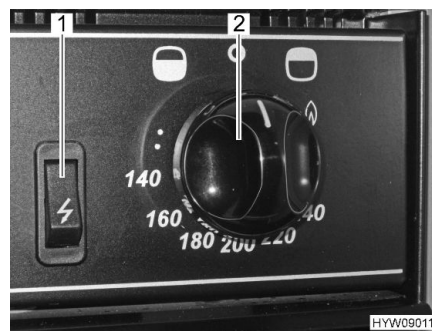


Fig. 89 Operating controls (gas oven with grill)

- Switching on:**
- Open the regulator tap on the gas bottle and the gas isolator tap "Oven".
 - Fully open the oven flap (Fig. 88,3).

- Switching on the oven:**
- Press the control knob (Fig. 88,2 and Fig. 89,2) and set it to the maximum setting anticlockwise (towards the oven symbol "🔥").
 - Press the control knob (Fig. 88,2 and Fig. 89,2) and hold it down for 5 to 10 seconds. Gas will stream into the burner.
 - Keep the ignition switch (Fig. 88,1 and Fig. 89,1) pressed until the flame burns.
 - Once the flame is burning, the control knob must be held down for another 10 to 15 seconds, until the thermocouple automatically keeps the gas supply open.
 - Release the control knob and turn to the desired setting.

- Switching on the grill:**
- Press the control knob (Fig. 88,2 and Fig. 89,2) and turn it clockwise (towards the grill symbol "🔥") in the direction of the flame symbol.
 - Press the control knob (Fig. 88,2 and Fig. 89,2) and hold it down for 5 to 10 seconds. Gas will stream into the burner.
 - Keep the ignition switch (Fig. 88,1 and Fig. 89,1) pressed until the flame burns.
 - Once the flame is burning, the control knob must be held down for another 10 to 15 seconds, until the thermocouple automatically keeps the gas supply open.
 - Release the control knob and turn to the desired setting.

- Switching off:**
- Turn the control knob (Fig. 88,2 and Fig. 89,2) to "0". The flame fades.
 - Close the gas isolator tap "Oven" and the regulator tap on the gas bottle.



10.3.3 Extractor hood (recirculating)



- ▶ Maintain a distance of 65 cm between the extractor hood and open flames.
- ▶ Do not flambé under the extractor hood.



- ▷ The appliance is connected to the 12 V power supply.
- ▷ Always switch on the extractor hood when cooking. It is advisable to switch on the extractor hood a few minutes before you start cooking. This causes the air to start moving and odours can be dissipated more quickly.
- ▷ After cooking, allow the air extraction to continue for a few minutes so that any remaining odours can be neutralised.
- ▷ The life of the bulbs can be extended by using the low lighting setting.
- ▷ Further information can be obtained in the instruction manual for the respective appliance.

Depending on the model, a recirculating extractor hood may be fitted above the cooker. The fan draws in the cooking steam above the cooker. An activated carbon filter and a grease filter clean the air that has been drawn in and it is then blown out again.



- 1 Switch for fan motor
- 2 Light switch

Fig. 90 Operation (extractor hood)

Switching on:

- Set the switch (Fig. 90,1) for the fan motor to the "☉" position (low fan speed) or the "●" position (high fan speed).
- Switch on the cooker lighting if necessary. Set the light switch (Fig. 90,2) to the "☉" position (low lighting) or "●" position (bright lighting).

Switching off:

- Set the switch (Fig. 90,1) for the fan motor to the central position "○".
- Set the light switch (Fig. 90,2) to the central position "○".

10.4 Refrigerator

During the journey, only operate the refrigerator via the 12 V power supply. At high ambient temperatures the refrigerator is unable to reach its full cooling power.



- ▷ When leaving the vehicle, always mount the refrigerator ventilation grill. Otherwise water can enter during rain.



10.4.1 Refrigerator ventilation grill

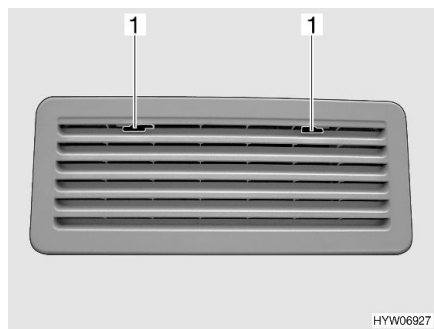


Fig. 91 Refrigerator ventilation grill (Thetford)

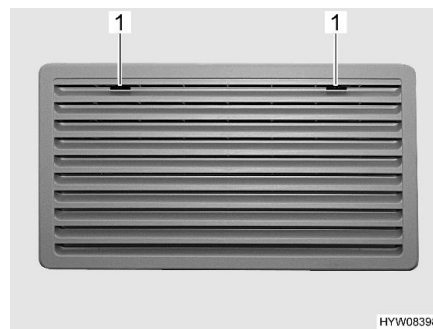


Fig. 92 Refrigerator ventilation grill, large (Thetford)

- Removal:**
- Move the locking device (Fig. 91,1 or Fig. 92,1) to the middle.
 - Remove refrigerator ventilation grill.

10.4.2 Operation (Thetford)



- ▷ Select only one energy source.
- ▷ Even when the 12 V power supply is switched off, a small electrical power flows which puts an extra load on the living area battery. Always switch off the refrigerator for a temporary lay-up.

Operating modes

The refrigerator has 3 operating modes:

- Gas operation
- 240 V operation
- 12 V operation

The operating mode is set with the operating controls on the refrigerator panel. Infinitely variable regulation of the cooling power is only possible with gas operation and when the refrigerator is operated with 240 V. It is not possible with 12 V operation.

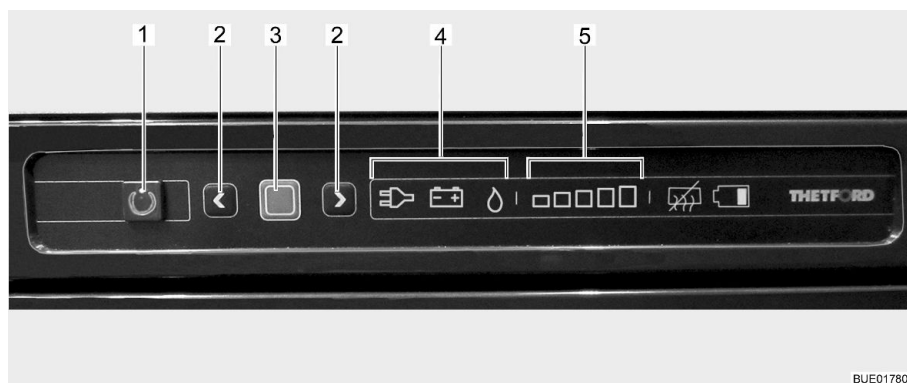


Fig. 93 Operating controls for the refrigerator

- 1 On/Off button
- 2 Arrow keys
- 3 Confirmation button
- 4 Indicator for operating mode (240 V operation/12 V operation/gas operation)
- 5 Indicator for cooling level (lowest - highest cooling level)

The current operating mode is indicated by an illuminated symbol (Fig. 93,4) on the operating unit.



- ▷ The refrigerator always requires a 12 V control voltage, regardless of which type of energy it is using. The control voltage is present as soon as the transformer/rectifier is switched on. Therefore the closed circuit current always flows even if the refrigerator is switched off. Always switch off the transformer/rectifier for a temporary lay-up.



- ▷ We recommend that the refrigerator be operated in 12 V operation when the vehicle is in motion.
When the vehicle is stationary, we advise you to operate the refrigerator in 240 V operation, assuming a 240 V connection is available.
In all other cases, the refrigerator can be operated in gas operation.

Refrigerating temperature control

When turned on the refrigerator automatically selects the thermostat position selected last. This position can be adjusted manually by using the arrow keys (Fig. 93,2). The illuminated bars of the cooling level indicator (Fig. 93,5) show the selected thermostat position. The refrigerating temperature for the three types of energy is set with the arrow keys. It takes a few hours till the refrigerator reaches its normal operating temperature. When changing over the operating mode the thermostat setting will be maintained. The refrigerating temperature is retained regardless of the type of energy being used.



- ▶ Never let gas escape unburned due to danger of explosion.
- ▶ It is not permitted to operate the refrigerator with car gas.



- ▷ Close the gas isolator tap "Refrigerator" when the refrigerator is operated electrically.

Switching on:

- For gas operation, open the regulator tap on the gas bottle and the gas isolator tap "Refrigerator".
- Press and hold the On/Off button (Fig. 93,1) for 1 second. Button (Fig. 93,1) lights up green. To save energy, after approximately 10 seconds the display is dimmed.
- Press and hold the confirmation button (Fig. 93,3) for about 2 seconds. The symbols for the operating modes (Fig. 93,4) are flashing.
- Press the arrow keys (Fig. 93,2) to change the operating mode.
- For gas operation, select the operating mode Gas using the arrow keys (Fig. 93,2). Gas supply is open. Ignition will take place automatically. A ticking sound can be heard until ignition has been completed successfully.
- Press confirmation button (Fig. 93,3).
- Press confirmation button (Fig. 93,3) again. The current cooling level is shown by the illuminated bars (Fig. 93,5).
- To change the setting, press the arrow keys (Fig. 93,2) until the desired setting is displayed.

Switching off:

- Press and hold the On/Off button (Fig. 93,1) for about 2 seconds. All lights go out. Refrigerator is switched off.
- In case of gas operation, close the gas isolator tap "Refrigerator" and the regulator tap on the gas bottle.



When operated with 12 V, the refrigerator draws power only from the starter battery of the vehicle. The starter battery only supplies the refrigerator with 12 V when the vehicle engine is running. If the vehicle engine is switched off, the cooling no longer operates. However the refrigerator continues to operate via the transformer/rectifier with a control voltage from the living room area battery. For this reason, change over to gas operation during prolonged driving breaks.



- ▷ Further information can be obtained from the separate instruction manual "Refrigerator".

10.4.3 Refrigerator door locking mechanism



- ▷ During the journey the refrigerator door must always be closed and locked in the closed position.



- ▷ Lock the refrigerator door in ventilation position when the refrigerator is switched off. This prevents mould forming.

There are two positions for locking the refrigerator door in place:

- Closed refrigerator door during travel and when the refrigerator is in operation
- Slightly opened refrigerator door as a ventilation position when the refrigerator is switched off

Thetford

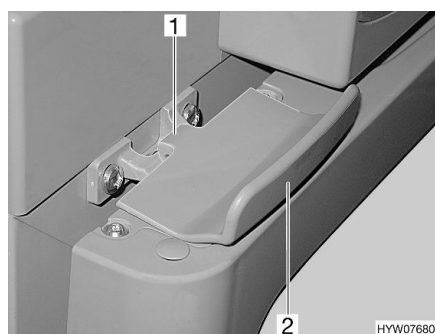


Fig. 94 Lock of refrigerator door, closed (Thetford)

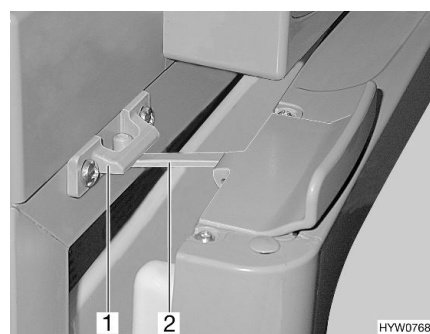


Fig. 95 Refrigerator door in ventilation position (Thetford)

- Opening:**
- Open the refrigerator door at the handle (Fig. 94,2). The lock (Fig. 94,1) is released automatically.

- Closing:**
- Fully close the refrigerator door. Ensure that the lock is engaged.

- Locking in the ventilation position:**
- Slightly open refrigerator door.
 - Open the lock (Fig. 95,2) and snap it into the locking catch (Fig. 95,1). The refrigerator door will then stay slightly open.



Chapter overview

This chapter contains instructions regarding the sanitary fittings of the vehicle. The instructions address the following topics:

- water tank
- waste water tank
- complete water system
- toilet compartment
- toilet

11.1 Water supply, general



- ▶ Fill water tank from supply systems that have been verified to provide drinking water quality.
- ▶ Only use such hoses or containers when filling that have been approved for use with drinking water.
- ▶ Thoroughly rinse filling hose or container with drinking water before use (2 to 3 times capacity).
- ▶ Empty filling hose or container completely after use and close openings of the filling hose or container.
- ▶ Water left standing in the water tank or in the water pipes becomes undrinkable after a short period. Therefore, before each use of the vehicle, thoroughly clean the water pipes and the water tank. After each use of the vehicle completely empty the water tank and the water pipes.
- ▶ In the case of lay-ups lasting more than a week disinfect the water system before using the vehicle (see chapter 12).



- ▷ If the vehicle is not used for several days or if it is not heated when there is a risk of frost, empty the entire water system. Make sure that the 12 V power supply on the panel is switched off. Otherwise, the water pump will overheat and may get damaged. Leave the water taps on in central position. Leave the safety/drainage valve (if there is one) and all drain cocks open. Frost damage to appliances, frost damage to the vehicle and deposits in water-carrying components can be avoided in this way.
- ▷ The water pump will overheat without water and can get damaged after one minute at the latest. Never operate water pump when the water tank is empty.

The vehicle is equipped with a fitted water tank. An electric water pump pumps the water to the individual water taps. Opening a water tap automatically switches on the water pump and pumps water to the tap.

The waste water tank collects the waste water. The water level in the water and waste water tanks can be checked on the panel.



- ▷ Before using the water fittings, the 12 V power supply on the panel must be switched on. Otherwise the water pump will not work.

Positions of the water pumps

The submerged pumps are located in the water tank.



11.2 Water tank

Depending on the model, the water tank holds between 97 l and 122 l.



- ▷ For driving safety and for regulatory reasons, when the vehicle is motion the fill quantity must be reduced. If the water is drained using the safety drainage handle (see section 11.2.4), a residual quantity of approximately 20 litres will remain in the water tank.

11.2.1 Drinking water filler neck with cap



Fig. 96 Cap for the drinking water filler neck

The drinking water filler neck is on the right or left side of the vehicle, depending on the model.

The drinking water filler neck is indicated by the symbol "☰" (Fig. 96,1). The cap is opened and closed using the key for the external flap locks.

- Opening:*
- Insert key into locking cylinder (Fig. 96,2) and turn a quarter turn in an anti-clockwise direction.
 - Remove cap.
 - Fill the water tank with drinking water.
- Closing:*
- Place the cap on the drinking water filler neck.
 - Turn key one quarter turn in a clockwise direction.
 - Remove the key.
 - Check that the cap sits firmly on the drinking water filler neck.

11.2.2 Filling the water system



- ▶ When filling the water tank, observe the maximum permissible gross weight of the vehicle. Luggage must be reduced accordingly when the water tank is full.



- ▷ The water pump will overheat without water and can get damaged after one minute at the latest. Never operate water pump when the water tank is empty.



- ▷ The water quantity can be monitored on the panel while the water tank is filled.



- Position the vehicle horizontally.
- Switch on the 12 V power supply on the panel.

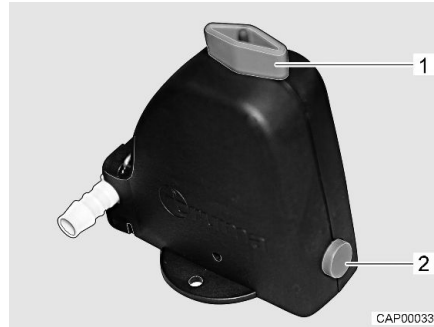


Fig. 97 Safety/drainage valve open

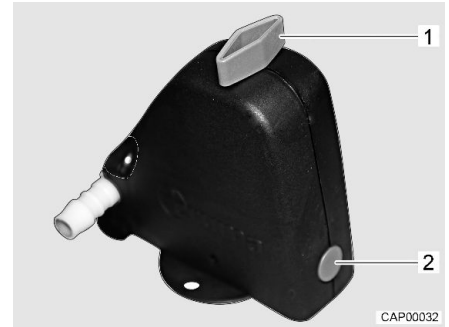


Fig. 98 Safety/drainage valve closed

- Close the safety/drainage valve. Turn the knob (Fig. 97,1) perpendicular to the safety/drainage valve and push the push button (Fig. 97,2) in. The closed safety/drainage valve is shown in Fig. 98. If the temperature is below 6 °C, the safety/drainage valve cannot be closed.
- Close all water taps.
- Close the drainage opening of the water tank.
- Open the drinking water filler neck on the outside of the vehicle.
- Fill the water tank with drinking water. Use a water hose, a water canister with a funnel or similar for filling.
- Set all the water taps to "Hot" and open them. The water pump is turned on. The warm water pipes are filled with water.
- Keep the water taps open until the water flowing out of the water taps has no bubbles in it. This is the only way to ensure that the boiler is full of water.
- Set all water taps to "Cold" and leave them open. This will fill the cold water pipes with water.
- Keep the water taps open until the water flowing out of the water taps has no bubbles in it.
- Close all water taps.
- Close drinking water filler neck.
- Check that the cap on the water tank is not leaking.

11.2.3 Topping up the water



- ▶ When filling the water tank, observe the maximum permissible gross weight of the vehicle. Luggage must be reduced accordingly when the water tank is full.

To fill the water tank with drinking water, proceed as follows:

- Open drinking water filler neck (Fig. 96).
- Fill the water tank with drinking water. Use a water hose, a water canister with a funnel or similar for filling.
- Close drinking water filler neck.



11.2.4 Reducing the water quantity for mobile operation



- ▶ When filling the water tank, observe the maximum permissible gross weight of the vehicle. Luggage must be reduced accordingly when the water tank is full.

Handle The handle is installed on the water tank.

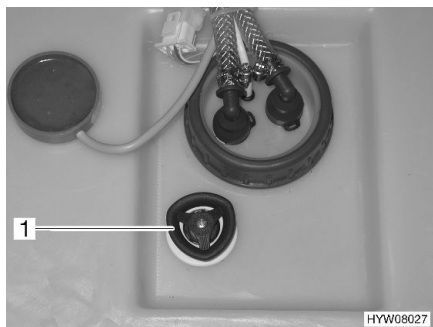


Fig. 99 Water tank with handle

- Closing:*
- Turn the handle (Fig. 99,1) on the water tank in a clockwise direction as far as it will go.
 - Fill the water tank with drinking water.
- Opening:*
- Turn the handle (Fig. 99,1) on the water tank in an anticlockwise direction as far as it will go. Excess water will drain away leaving approx. 20 litres in the tank.

11.2.5 Draining water

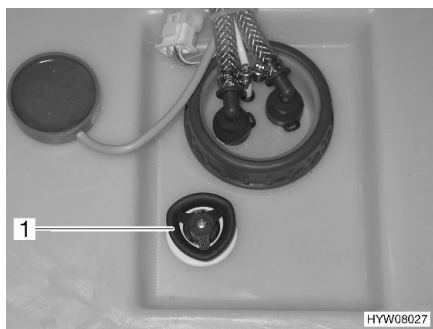


Fig. 100 Water tank with handle

- Turn the handle (Fig. 100,1) on the water tank in an anticlockwise direction as far as possible beyond the resistance to fully open the drainage opening.



11.2.6 Emptying the water system



- ▷ If the vehicle is not used for several days or if it is not heated when there is a risk of frost, empty the entire water system. Make sure that the 12 V power supply on the panel is switched off. Otherwise, the water pump will overheat and may get damaged. Leave the water taps on in central position. Leave the safety/drainage valve (if there is one) and all drain cocks open. Frost damage to appliances, frost damage to the vehicle and deposits in water-carrying components can be avoided in this way.

To empty and ventilate the water system, proceed as follows. This prevents frost damage and deposits:

- Position the vehicle horizontally.
- Switch off 240 V power supply. In order to do this, switch off the 240 V fuse (see section 11.2.5). The external 240 V connection can remain connected to charge the batteries.
- Switch off the 12 V power supply on the panel.
- Shut off the production of hot water (see section 10.2.4).

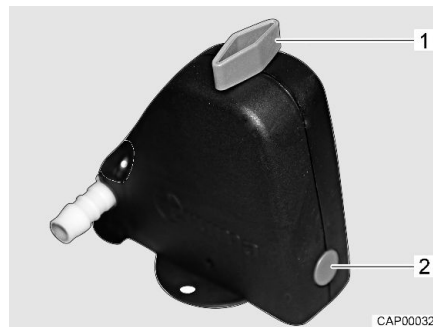


Fig. 101 Safety/drainage valve closed

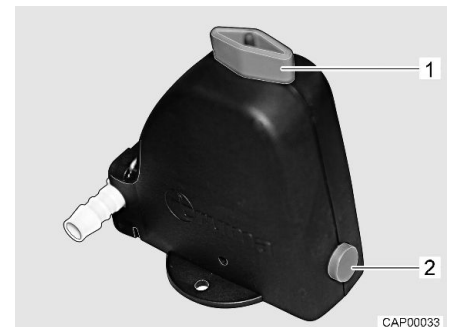


Fig. 102 Safety/drainage valve open

- Open the safety/drainage valve (Fig. 101). To do this turn the knob (Fig. 101,1) parallel to the safety/drainage valve. The push button (Fig. 101,2) jumps out. The open safety/drainage valve is shown in Fig. 102.
- Open the water tank drain (see section 11.2.5).
- Open all water taps and set to the central position.
- Hang the shower handset up in the shower position.
- Hold the water pump up until the water pipes are completely empty.
- Check whether the water tank is completely empty.
- Blow out the remaining water in the water pipes (max. 0.5 bar). To do this, remove the pipe from the water pump and blow into the pipe.
- Clean the water tank and then rinse it out thoroughly.
- Let the water system dry for as long as possible.
- After emptying, leave all water taps on in the central position.
- Keep the safety/drainage valve open.



11.2.7 Position of the safety/drainage valve

The position of the safety/drainage valve varies depending on the model.

Model	Position ¹⁾
T58/135 T64/348	Underneath the bed, in the room next to the heater (accessible through an opening in the cover)
T60/132	In the wardrobe, bottom compartment in the shelf
T65/334	In the storage compartment in front of the double bed
T66/337	In the storage cupboard underneath the single bed, open front cover
T67/448 T68/447 I68	In the wardrobe, at the bottom right-hand side on the floor
T69L/449 T69S/339 I69L	Underneath the double bed, in the cabinet on the left-hand side
A68/361 A70/464	In the wardrobe, at the bottom
A72/461	In the tall cupboard of the kitchen, in the bottom area

¹⁾ The information on left-hand and right-hand are always given looking in the direction of travel

11.3 Waste water tank



- ▷ In case of frost add so much anti-freeze (such as kitchen salt) to the waste water tank so that the waste water cannot freeze.
- ▷ Never pour boiling water directly into the sink outlet. Boiling water could cause deformation and leaks in the waste water pipe system.



- ▷ Only empty the waste water tank at disposal stations, camping sites or caravan sites especially provided for this purpose.

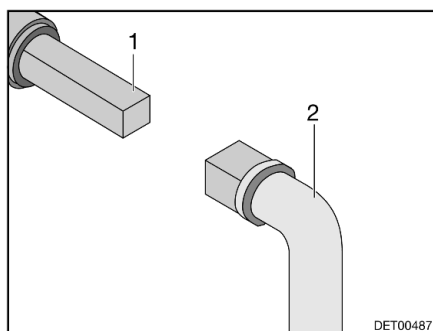


Fig. 103 Operation of the waste water tap

Depending on the model, the waste water tap for waste water disposal is located on the left or right hand side of the vehicle.

The square bolt for opening the waste water tap is directly accessible under the vehicle floor.



- Emptying:**
- Place key (Fig. 103,2) onto the square bolt (Fig. 103,1).
 - In order to open the waste water tap, turn the square bolt a quarter turn.
 - Completely empty waste water tank.
 - To close the waste water tap, turn the square bolt back as far as it will go.

11.4 Toilet compartment



- ▷ Do not transport any loads in the shower tray. The shower tray or other items of equipment in the toilet compartment can be damaged.

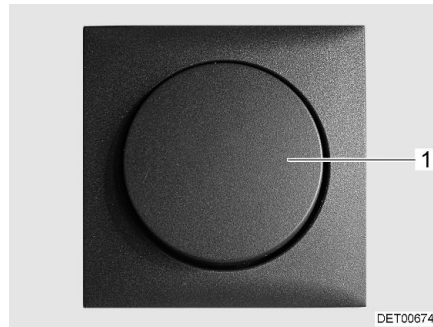


Fig. 104 Light switch for toilet compartment

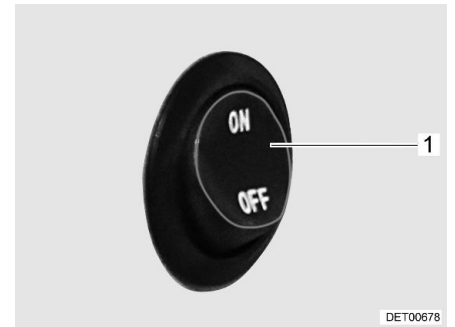


Fig. 105 Light switch for toilet compartment

The flip switches for the toilet compartment lighting are installed in different places in the toilet compartment depending on the model.

For example, the light switch (Fig. 104,1 or Fig. 105,1) of the toilet compartment is located in the area below the bathroom cabinet or below the wash basin.



- ▷ For ventilation purposes during or after a shower, and for drying wet clothing, close the toilet compartment door and open the window or the toilet compartment skylight. This improves the air circulation.
- ▷ Close the shower curtain completely when showering, so that no water is able to enter the area between the wash room wall and the shower tray.
- ▷ After taking a shower, rinse soap residue from the shower tray, otherwise cracks can appear in the shower tray over time.
- ▷ After using the shower, wipe it dry to prevent moisture from collecting.
- ▷ Further information about cleaning the toilet compartment can be found in the section 12.2.



Fig. 106 Clothes rail to dry clothes

Clothes rail to dry clothes

The folding clothes rail (Fig. 106,1) under the skylight can be used to hang towels and clothes to dry.

Shower grate insert

The shower grate insert is made of solid wood. The shower grate insert protects the shower tray and provides a dry floor, even after taking a shower.



Fig. 107 Shower grate insert

Observe the following for a long service life:

- Before taking a shower, take the shower grate insert (Fig. 107,1) out of the shower.
- After taking a shower, put the shower grate insert back into the shower tray.
- At least twice a year, apply a commercial solid wood oil to the shower grate insert using a lint-free cloth in fibre direction (observe the manufacturer's instructions).

11.5 Vario toilet compartment



- ▷ Only remove the inner part of the toilet compartment panelling when the toilet door is closed.



- ▷ Depending on the model, the Vario toilet compartment is installed reverse to the one shown here. The conversion is then also done reverse to the Vario toilet compartment shown.

Depending on the model, the vehicle is fitted with a Vario toilet compartment. A Vario toilet compartment can be changed with few maneuvers so that when the shower is in use, the toilet is available in its own enclosed cubicle. This protects the toilet area from water spray.



Fig. 108 Lock, toilet compartment panelling

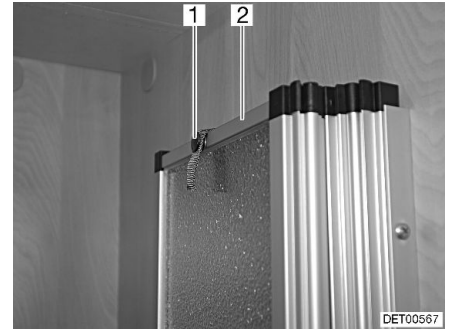


Fig. 109 Securing attachment, shower partition

Converting into a shower cubicle:

- Enter toilet compartment and close toilet door from the inside and lock.
- Put the latch (Fig. 108,2) in an upright position and unfold the inner part (Fig. 108,1) of the toilet compartment panelling.
- Loosen the retaining strap (Fig. 109,1) of the shower partition (Fig. 109,2) and pull out the shower partition.
- Press the shower partition against the inner part of the toilet compartment panelling.

The shower compartment is set up and can be used.

Conversion to toilet compartment:

- Fold up the shower partition (Fig. 109,2) and fasten with the retaining strap (Fig. 109,1).
- Fold up the inner part (Fig. 108,1) of the toilet compartment panelling and turn the latch (Fig. 108,2) to a horizontal position.

11.6 Toilet

11.6.1 Thetford toilet



- ▷ If there is any risk of frost and the vehicle is not heated, empty the Thetford cassette.
- ▷ Do not sit on the lid of the toilet. The lid is not designed to bear the weight of a person and could break.
- ▷ Use a suitable chemical for this toilet. The ventilation will merely remove the odour but not germs and gases. Germs and gases will have a detrimental effect on the sealing rubbers.



- ▷ Further information can be obtained in the manufacturer's instruction manual.



- ▷ Only empty the Thetford cassette at disposal stations, at camping sites or caravan sites, that are especially provided for this purpose.



Swivel toilet The flushing of the Thetford toilet is fed directly from the water system of the vehicle. The toilet bowl can be moved into the optimal position.

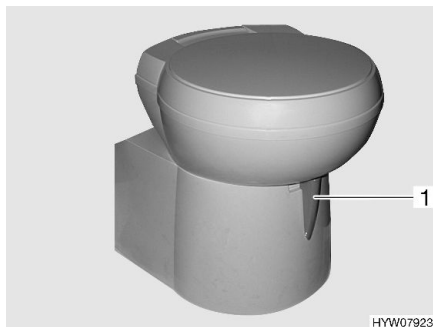


Fig. 110 Thetford toilet bowl (swivelling)

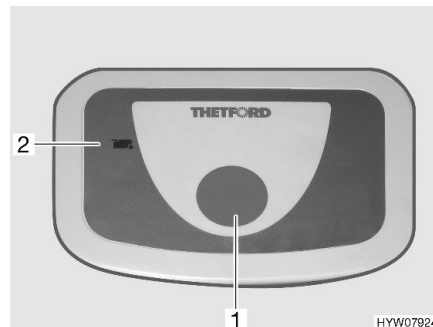


Fig. 111 Flush button/indicator lamp (Thetford toilet)

The operating unit is located close to the toilet bowl.

- Flushing:*
- Before flushing open the sliding trap of the Thetford toilet. To do this, push the slide lever (Fig. 110,1) in an anticlockwise direction.
 - For flushing, press the blue flush button (Fig. 111,1).
 - After flushing close the sliding trap. To do this, push the slide lever in a clockwise direction.

The indicator lamp (Fig. 111,2) lights up whenever the sewage tank has to be emptied.

- Emptying:*
- Turn the slide lever (Fig. 110,1) in a clockwise direction. The sliding trap is closed. To empty, the sliding trap in the Thetford toilet **must** be closed.
 - Remove and empty the Thetford cassette.

Toilet with fixed seat The flushing of the toilet is fed from the water system of the vehicle.

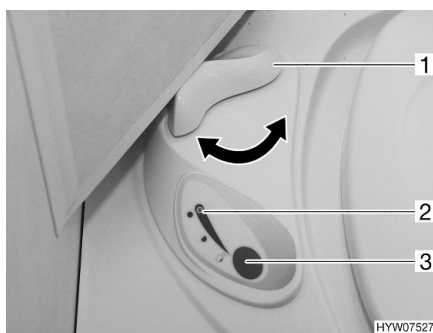


Fig. 112 Operating unit Thetford toilet

- Flushing:*
- Before flushing open the sliding trap of the Thetford toilet. To do this, turn the slide lever (Fig. 112,1) in an anticlockwise direction.
 - For flushing, press the blue flush button (Fig. 112,3).
 - After flushing close the sliding trap. To do this turn the slide lever (Fig. 112,1) in a clockwise direction.

The indicator lamp (Fig. 112,2) lights up whenever the Thetford cassette has to be emptied.



- Emptying:*
- Turn the slide lever (Fig. 112,1) in a clockwise direction. The sliding trap is closed. To empty, the sliding trap in the Thetford toilet **must** be closed.
 - Remove and empty the Thetford cassette.

11.6.2 Emptying the sewage tank



- ▷ The sewage tank can only be taken out if the sliding trap is closed.



Fig. 113 Flap for the sewage tank



Fig. 114 Sewage tank

- Slide the slide lever on the toilet bowl in a clockwise direction. The sliding trap is closed.
- Open the flap for the sewage tank on the outside of the vehicle. Insert the key into the locking cylinder (Fig. 113,1) of the push-button lock and turn a quarter turn in a clockwise direction.
- Remove the key.
- Press both push-button locks (Fig. 113,2) simultaneously with your thumb and open the flap for the sewage tank.
- Swivel flap fully upwards and carefully set on the exterior wall. The flap is kept open magnetically.
- Pull the retaining clip (Fig. 114,2) upwards and pull out the sewage tank (Fig. 114,1).
- Completely empty the sewage tank at disposal stations that are especially provided for this purpose.



- ▷ Actuate the aeration knob on the sewage tank with your thumb to empty it completely.



11.6.3 Winter operation



- ▷ Do not use antifreeze. Antifreeze can damage the toilet.

If the toilet, the water tank and the sewage tank (cassette) are in a frost-protected part of the vehicle, the toilet can also be used in the winter.

If the toilet, the water tank and the sewage tank (cassette) are not in a frost-protected part of the vehicle, empty the water tank, the sewage tank and the water pipes if there is a risk of frost. This prevents frost damage.

11.6.4 Temporary lay-up



- ▷ If the toilet is not to be used for an extended period, empty the water tank, the sewage tank and the water pipes.

Laying up the toilet:

- Empty the water tank.
- Flush the toilet until no more water runs into the toilet.
- Empty the sewage tank (cassette).
- Rinse the sewage tank thoroughly.
- Leave the drainage neck on the sewage tank open.
- Let the sewage tank dry for as long as possible.



Chapter overview

This chapter contains instructions regarding the care of the vehicle.

The instructions address the following topics:

- exterior of the vehicle
- interior
- water system
- extractor hood
- winter operation

At the end of the chapter there is a checklist of measures you must carry out if you are not going to use the vehicle for an extended period of time.

The checklist address the following topics:

- temporary lay-up
- winter lay-up
- start-up after a lay-up

12.1 External care

12.1.1 General

Standard external care consists of regular washing. The use and the environmental conditions will determine how often the vehicle needs to be washed. Wash the vehicle more frequently in areas which are exposed to heavy air pollution or heavy traffic or roads treated with de-icing salts. If the vehicle is exposed to salty and humid air (coastal areas, humid climates), wash the vehicle more frequently.

Do not park under trees if at all possible. The resin-like discharge which many trees secrete, give the paintwork a matt look and can promote the onset of corrosion.

Wash off bird droppings straight away and thoroughly, as the acid it contains is extremely corrosive.

12.1.2 Washing with a high-pressure cleaner



- ▷ Do not clean the tyres with a high-pressure cleaner. The tyres might be damaged.
- ▷ Do not spray external applications (deco-films) directly with the high-pressure cleaner. The external applications could come off.

Before cleaning the vehicle with a high-pressure cleaner, observe the operating instructions of the high-pressure cleaner.

When cleaning with the nozzle for circular jet between the vehicle and the cleaning nozzle, maintain a minimum distance of approx. 700 mm.

Take into consideration that the jet of water comes out of the cleaning nozzle with pressure. The vehicle may be damaged by incorrect handling of the high-pressure cleaner. The temperature of the water should not be above 60 °C. Keep the jet of water in constant movement during the washing process. Do not direct the water jet at clearances, built-in electrical parts, plugs, seals, the ventilation grill or the skylights. The vehicle may be damaged or water may enter the interior.



12.1.3 Washing the vehicle



- ▷ Never clean the vehicle in the car wash. Water can penetrate the refrigerator grills, the waste gas vent or the forced ventilations. The vehicle could be damaged.
- Wash the vehicle only on a washing site intended for this purpose. Avoid full sunshine. Observe environmental measures.
- Only clean external applications and synthetic parts with plenty of warm water, dish washing liquid and soft cloth.
- Wash down the vehicle with plenty of water, a clean sponge or a soft brush. In the case of stubborn dirt add dish washing liquid to the water.
- Painted exterior walls may also be cleaned with a caravan cleaner.
- Add-on parts made of glass-fibre reinforced plastic (GRP) require a regular follow-up treatment with a polisher. This way these parts will not turn yellow and the sealing of the surface remains intact.
- Treat rubber seals on doors and storage flaps with a conventional rubber care product.
- Treat locking cylinder of doors and storage flaps with graphite dust.

12.1.4 Windows of acrylic glass



Acrylic glass windows are delicate and require very careful handling.

- ▷ Never rub acrylic glass windows dry as dust particles might damage the surface!
- ▷ Only clean acrylic glass windows with plenty of warm water, some dish washing liquid and a soft cloth.
- ▷ Never use glass cleaning agents with chemical, abrasive or alcohol-containing additives. Premature brittleness of the panes and associated cracks may result from their use.
- ▷ Avoid contact of cleansing agents used for the body (e.g. tar- or silicone-removing agents) with acrylic glass.
- ▷ Do not clean vehicle in car wash.
- ▷ Do not attach stickers to the acrylic glass windows.
- ▷ Having cleaned the vehicle rinse acrylic glass with sufficient clear water.
- ▷ Treat rubber seals with a conventional rubber care product.



- ▷ An acrylic glass cleanser with antistatic effect is suitable for a follow-up treatment. Small scratches can be treated with an acrylic glass polish. These agents are available at the accessories shop.

12.1.5 Underbody

The underbody of the vehicle is partly coated with an age-resistant underbody protection. Should the underbody protection be damaged, repair immediately. Do not treat areas coated with underbody protection with spray oil.



- ▷ Only use products approved by the manufacturer. Our authorised dealers and service centres will be happy to advise you.



12.1.6 Entrance step

If the entrance step is lubricated, coarse particles of dirt can settle on the lubricant during the journey and cause damage to the operating mechanism of the entrance step. Therefore, do not lubricate the moving parts of the entrance step.

12.2 Interior care



- ▷ If possible, treat stains immediately.
- ▷ Acrylic glass windows are delicate and require very careful handling (see section 12.1.4).
- ▷ Synthetic parts in the toilet and living area are very delicate and should be treated with care. Do not use solvents, alcohol-containing cleansers or scourers. This procedure will help you to avoid brittleness and formation of cracks.
- ▷ Hair colourants, nail varnish, cigarette ash and similar substances may cause permanent stains or discolouration. For this reason, you should prevent these substances from getting onto plastic parts. If they do get onto plastic parts, you should remove these substances immediately.
- ▷ Do not pour any corrosive agents into the drain holes. Never pour boiling water directly into the drain holes. Corrosive agents and boiling water cause damage to drainage pipes and siphon traps.
- ▷ Do not use vinegar based products to clean the toilet and water system, or for decalcification of the water system. Vinegar-based products may cause damage to seals or parts of the installation. Use standard decalcifying products for decalcification.
- ▷ Save water. Mop up all remaining water.
- ▷ Vacuum off carpets and cushions with a suitable brush attachment.



- ▷ For information about the use of maintenance products, our representatives and service centres will be glad to advise.
- Surface and knobs of furniture, lamps and synthetic parts in the toilet and living area should be cleaned with water and a wool cloth. A mild cleanser may be added to the water. If required, use furniture polish for the painted surfaces.
- Clean upholstery with dry foam specially manufactured for the use on upholstery or with the foam of a mild detergent. Protect upholstery from direct sunlight so that it does not lose its colour.
- Curtains and net curtains should be dry cleaned.
- Vacuum clean the carpet, if necessary clean with carpet shampoo.
- Clean PVC-floor covering with a mild, soapy cleanser for PVC floors. Do not place carpet on wet PVC-floor covering. The carpet and the PVC-floor covering may stick together.
- Never clean the sink or the gas cooker with a scourer. Avoid anything which may cause scratching or grooves.
- Clean gas cooker only with a moist cloth. Prevent any water from penetrating the gas cooker. Water may damage the gas cooker.



- Insect screen fabric on the door, windows, and skylights: Always remove insect residues or dirt immediately. Otherwise the fabric could be damaged. Wasps and birds could cause damages when feeding on the adhered residues. A microfibre cloth is recommended for the cleaning of the insect screen fabric. Only use cleaning agents if they are pH neutral and do not contain any solvents. If required, you can carry out a careful previous cleaning using a soft brush or a fine brush attachment on a vacuum cleaner.
- Brush blinds with a soft brush or vacuum with the brush attachment of the vacuum cleaner. Grease or stubborn dirt may be removed with a mild soap at 30 °C (curd soap).
- Brush Roman shades with a soft brush or vacuum with the brush attachment of the vacuum cleaner. Grease or stubborn dirt may be removed with a mild soap at 30 °C (curd soap).
- Unrolled seat belts can be cleaned with warm soapsuds. The seat belt must be completely dry before being rolled up.

12.3 Water system

12.3.1 Cleaning the water tank

- Empty the water tank and close the drainage opening.
- Remove the cap of the water tank.
- Fill water tank with water and some washing-up liquid (do not use any scourers).
- Using a trade standard brush for washing dishes, scrub the water tank until there is no longer any visible deposit.
- Scrub also the pump housing.
- If possible, clean fresh water sensors through the cleaning openings by hand.
- Rinse water tank with copious amounts of drinking water.



- ▷ If, due to the design of the water tank, it is not possible to clean the water tank mechanically: Use a suitable chemical cleaning agent.
The authorised dealers would be happy to assist you in choosing a suitable cleaning agent.
Follow the cleaning agent manufacturer's instructions.

12.3.2 Cleaning the water pipes



- ▷ Only use suitable cleaning agents as sold by the specialist trade.
- ▷ The cleaning agent must meet national regulations and be approved (if required).



- ▷ Collect any emerging mixture of water and cleaning agent for correct disposal.



- Empty the water system.
- Close all drainage openings and drain cocks.
- Fill mixture of water and cleaning agent into the water tank. Observe the manufacturer's instructions regarding the mixing ratio.
- Open the drain cocks one by one.
- Leave the drain cocks open until the mixture of water and cleaning agent has reached the respective drain.
- Close the drain cocks.
- Set all the water taps to "Hot" and open them.
- Leave the water taps open until the mixture of water and cleaning agent has reached the drain.
- Set all water taps to "Cold" and open them.
- Leave the water taps open until the mixture of water and cleaning agent has reached the drain.
- Close all water taps.
- Flush the toilet several times.
- Allow the cleaning agent to act in accordance with the manufacturer's instructions.
- Empty the water system. Collect the mixture of water and cleaning agent for correct disposal.
- For rinsing fill the entire water system with drinking water and empty again several times over.

12.3.3 Disinfecting the water system



- ▷ Only use suitable disinfectants as sold by the specialist trade.
- ▷ The disinfectant must meet national regulations and be approved (if required).



- ▷ Collect any emerging mixture of water and disinfectant for correct disposal.

When disinfecting the water system, proceed the same way as when cleaning the water pipes (see section 12.3.2). Simply use disinfectant instead of cleaning agent.

12.3.4 Waste water tank

Clean the waste water tank after every use of the vehicle.

Cleaning:

- Empty the waste water tank.
- Thoroughly rinse out the waste water tank with fresh water.
- If possible, clean waste water sensors through the cleaning opening by hand.



12.4 Extractor hood (recirculating)

Clean the extractor hood grease filter occasionally. How often cleaning is necessary depends on how often the extractor hood is used. Do not wait to clean the grease filter until the performance of the extractor hood has noticeably decreased.

An active carbon filter has been installed in the extractor hood for the filtering of odours. Under normal use conditions, the active carbon filter should be replaced every six months or once during the season.



Fig. 115 Unscrewing the lower cover



Fig. 116 Removing the grease filter

Cleaning the grease filter:

- Unscrew the two cross-head screws (Fig. 115,1) and remove together with the washers.
- Unhook the lower cover (Fig. 116,2).
- Remove the grease filter (Fig. 116,3) upwards.
- Clean the grease filter using water and washing-up liquid. Alternatively, the grease filter can be cleaned in the dishwasher.
- Leave the grease filter to dry.
- Place the grease filter into the guides on the lower cover from above.
- Hook the lower cover into the extractor hood.
- Pivot up the lower cover and secure in place with two cross-head screws and washers.

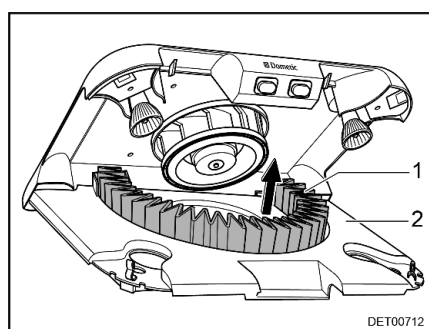


Fig. 117 Changing the active carbon filter

Changing the active carbon filter:

- Open the housing as described in "Cleaning the grease filter".
- Release the filter holder (Fig. 116,1) out of the lock at the front and swivel it downwards.
- Remove the active carbon filter (Fig. 117,1) of the holder in upward direction.
- Insert a new active carbon filter.



- Swivel the filter holder (Fig. 117,2) upwards until it engages.
- Close the housing as described in "Cleaning the grease filter".



- ▷ Further information can be obtained in the instruction manual for the respective appliance.

12.5 Winter care

De-icing salt damages the underbody and the parts open to water spray. We recommend that you wash the vehicle more frequently during wintertime. Mechanical and surface treated parts and the underside are under particular strain, and should therefore be cleaned thoroughly.



- ▷ If there is any risk of frost, always run heater at a minimum of 15 °C. Switch the circulation fan (if there is one) to automatic. In the case of extreme external temperatures, the furniture flaps and doors should be left slightly open. The inflowing warm air can help prevent the freezing of water pipes, for example, and counteract the formation of condensation in the storage spaces.
- ▷ If there is any risk of frost, cover the outside surface of the windows with winter insulation mats.

12.5.1 Preparations

- Check the vehicle for paint and rust damage. Repair damage as necessary.
- Make certain that water cannot penetrate the automatic floor ventilation system and the heater.
- Use a wax-based rust inhibitor to protect the metal parts of the underbody.
- Use appropriate protection for external painted surfaces.

12.5.2 Winter operation

During winter operation, condensation develops when the vehicle is occupied under low-temperature conditions. To ensure good interior air quality and avoid vehicle damage from condensation, sufficient ventilation is essential.

- When heating the vehicle, the heater should be at the highest setting and roof storage cabinets, curtains and blinds should be opened. This ensures optimal ventilation.
- In the morning, lift up all cushions, air out storage boxes and dry any damp areas.



- ▷ If condensation has still developed, just wipe it off.

12.5.3 At the end of the winter season

- Thoroughly clean the underbody of the vehicle and the engine. When this is done, corrosion-inducing anti-freeze agents (salts, alkaline residues) are removed.
- Clean the exterior and use regular car wax to protect metal surfaces.



12.6 Lay-up

12.6.1 Temporary lay-up



- ▶ If the vehicle has been stationary for a long period (approx. 10 months) have the braking and gas systems checked by an authorised specialist workshop.
- ▶ Take into consideration that water is undrinkable after only a short time.
- ▶ Animal damage to cables can lead to short circuits. Fire hazard!


Animals (especially mice) can cause great damage to the interior of the vehicle. This is especially true if the animal remains undisturbed in a parked vehicle.

The animals can get into the vehicle at an opportune moment and hide from view.


To keep damages from animals to a minimum or to avoid them altogether, regularly check the vehicle for damage or animal traces. This is especially important approx. 24 hours after parking the vehicle in storage.

If animal traces are found, contact the authorised dealer or service centre. If damage to cables has occurred, they can result in short circuits. The vehicle could catch fire.

Before laying up the vehicle, go through the following checklist:

	Activities	Done
Base vehicle	Completely fill fuel tank. This prevents corrosion damage within the fuel tank system	
	Jack up vehicle so that the wheels do not bear any load, or move vehicle every 4 weeks. This prevents any pressure points from occurring on tyres and wheel bearings	
	Protect the tyres from direct exposure to the sun. Danger of formation of cracks!	
	Inflate tyres up to the recommended maximum pressure	
	Always provide for sufficient ventilation in the underbody area	
	 ▶ Humidity or lack of oxygen e.g. by covering with plastic film may cause optical irregularities to the underbody. In addition observe the notes in the operating manual of the base vehicle	
Body	All vents should be sealed with the appropriate caps and all other openings (apart from forced ventilations) should also be sealed. This prevents animals (e.g. mice) from gaining entry	
	Air the interior, all storage spaces accessible from the outside, and the parking space (e.g. garage) every 3 weeks in order to prevent the occurrence of condensation and resulting mould formation	
Interior	Place upholstery in an upright position for ventilation, and cover	
	Clean refrigerator	
	Allow refrigerator and freezer compartment doors to remain slightly open	
	Search for traces of animals that have gained entry	



	Activities	Done
Gas system	Close regulator tap on the gas bottle	
	Close all gas isolator taps	
	Always remove gas bottles from the gas bottle compartment, even if they are empty	
Electrical system	Fully charge living area and starter battery	
	 ▷ Charge the battery for at least 20 hours before laying up.	
	Disconnect the living area battery from the 12 V power supply	
Water system	Empty the entire water system. Blow out the residual water from the water pipes (0.5 bar max.). Leave the water taps on in central position. Leave the safety/drainage valve (if there is one) and all drain cocks open. Observe the notes in chapter 11	

12.6.2 Winter lay-up

Additional measures are required if laying up the vehicle over winter:


	Activities	Done
Base vehicle	Clean body and underbody thoroughly and spray with hot wax or protect with varnish	
	Fill fuel tank with winter diesel	
	Check antifreeze in the cooling water	
	Rectify damage to the paintwork	
	Fill in washer fluid with frost protection	
Body	Keep the forced ventilation open	
	Clean and lubricate the mounted steady legs	
	Clean and grease all door and flap hinges	
	Brush oil or glycerine on all locking mechanisms	
	Treat all rubber seals with a conventional rubber care product	
	Use graphite dust to treat locking cylinders	
Interior	Set up the de-humidifier (granulate)	
	Remove cushions and mattresses from the vehicle and store them in a dry place	
	Air the interior every 3 weeks	
	Empty all cabinets and storage compartments, open flaps, doors and drawers	
	Thoroughly clean the interior	
	If there is a risk of frost, do not leave the flat screen in the vehicle	
Electrical system	Remove starter and living area batteries and store in a place protected from frost (see chapter 9)	



	Activities	Done
Water system	Clean the water system using a cleaning agent from a specialised store	
Complete vehicle	Arrange the tarpaulins in such a way that the ventilation openings are not covered, or use porous tarpaulins	

12.6.3 Starting up the vehicle after a temporary lay-up or after lay-up over winter

Go through the following checklist before start-up:

	Activities	Done
Base vehicle	Check the tyre pressure on all tyres	
	Check the tyre pressure of the spare wheel	
Body	Clean the pivot bearing of the entrance step	
	Check the functioning of the fitted steady legs	
	Check that the doors, windows and skylights are working properly	
	Check the function of all external locks	
	Remove the cover from the waste gas vent of the heater (if there is one)	
	Remove the winter cover from the refrigerator grills (if there is one)	
Gas system	Put the gas bottles in the gas bottle compartment, tie down and connect to the gas pressure regulator	
Electrical system	Connect to 240 V power supply using the external socket	
	Fully charge living area and starter battery	
	 ▷ Charge the battery for at least 20 hours after lay-up.	
	Connect the living area battery with the 12 V power supply (see chapter 9)	
	Check that the electrical system are working, e.g. interior light, socket and all installed electrical appliances	
Water system	Disinfect water pipes and water tank	
	Check the functionality of the operating lever for the waste water tank	
	Close safety/drainage valve, drain cocks and water taps	
	Check the safety/drainage valve, water taps, drain cocks and water distributors for leaks	
Appliances	Check the function of the refrigerator	
	Check the function of the heater/boiler	
	Check the function of the gas cooker	



Chapter overview

This chapter contains instructions about inspection and maintenance work concerning the vehicle.

The maintenance instructions address the following topics:

- replacing light bulbs

At the end of the chapter you will find important instructions on how to obtain spare parts.

13.1 Inspection work

Like any technical appliance, the vehicle must be inspected at regular intervals.

This inspection work must be carried out by qualified personnel.

Special technical knowledge, which cannot be taught within the framework of this instruction manual, is required for these tasks. Personnel with this technical knowledge are available for assistance at all authorised dealers and service centres. Their experience and regular technical instruction by the factory as well as equipment and tools guarantee expert and up-to-date inspection of the vehicle.

Have chassis inspections confirmed in the chassis manufacturer's customer service booklet.

13.2 Maintenance work

As with every machine, this vehicle requires maintenance. The extent and frequency of the maintenance work required depend on conditions of operation and use. More difficult operating conditions make it necessary to service the vehicle more often.

Have the base vehicle and the appliances serviced at the intervals specified in the corresponding instruction manuals.

13.3 Replacing bulbs, external



- ▶ Bulbs and light fittings can be extremely hot. Therefore, allow lights to cool down before changing bulbs.
- ▶ Store bulbs in a safe place inaccessible to children.
- ▶ Do not use any bulb that has been dropped or which shows scratches in its glass. The bulb might burst.



- ▷ A new bulb should not be touched with the fingers. Use a cloth when installing the new bulb.
- ▷ Only use bulbs of the same type and with the correct wattage.
- ▷ If LEDs in lights are defect, contact an authorised dealer or service centre.



Types of bulbs

Different types of bulbs are used in the vehicle. Below, we have described how to change the different types of bulbs.

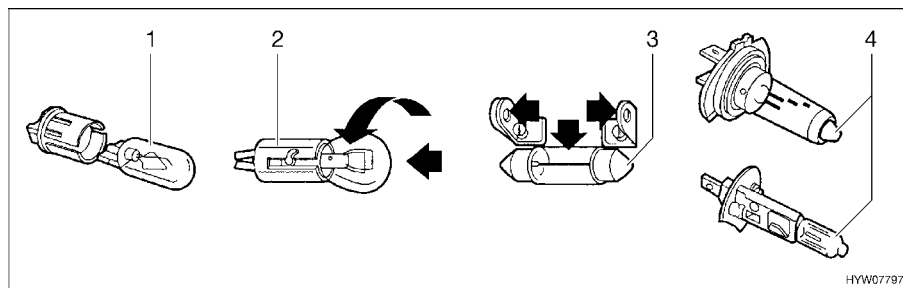


Fig. 118 Types of bulbs

Pos. in Fig. 118	Fixture type/bulb type	Changing
1	Plug-in fixture	To remove, pull out the bulb To mount, push the bulb into the socket with gentle pressure
2	Bayonet socket	To remove, press the bulb down and turn in an anticlockwise direction To insert, place the bulb in the socket and turn in a clockwise direction
3	Cylindrical bulbs	To remove and to insert, carefully bend the contacts of the lamp holder outwards
4	Halogen bulb	To remove, release retaining springs After inserting, hook the retaining springs again

13.3.1 Front lights

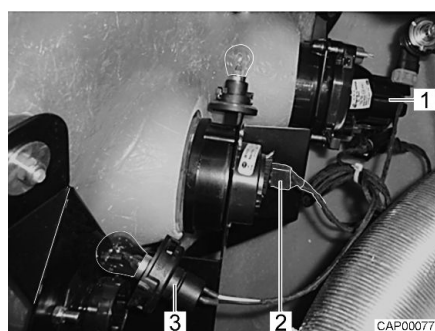
Model T, model A

The lamps for low beam, main beam and parking light as well as for the direction indicator are part of the basic vehicle. Replacement of light bulbs is described in the instruction manual of the base vehicle.

Model I

The bulbs for headlights, daytime running light, and direction indicator are changed from the engine compartment.

The bulb in the direction indicator on the side is changed from outside.



- 1 High/low beam headlight (H7, 12 V/ 55 W)
- 2 Daytime running light (12 V/21 W)
- 3 Direction indicator (12 V/21 W orange)

Fig. 119 Front lighting (seen from engine compartment)



- Open bonnet (see chapter 4).
- Insert your hand behind the lamp holder of the defective bulb.
- Turn the lamp holder with the bulb in an anticlockwise direction and remove it.
- Turn bulb in an anticlockwise direction and remove from the holder.
- Put in a new bulb.

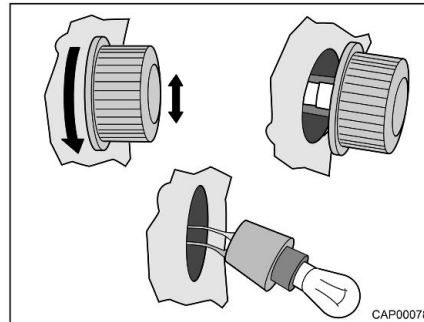
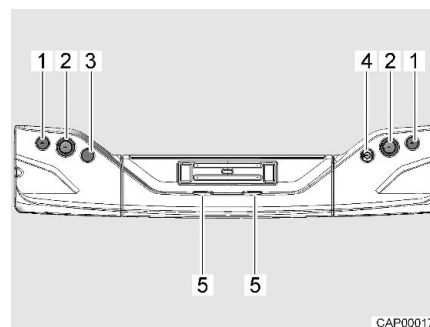


Fig. 120 Direction indicator on the side (12 V/5 W)



- Carefully turn the housing of the direction indicator and move it upwards and downwards at the same time.
- ▷ To be able to remove the housing, it has to be turned until the holding lugs of the housing are in horizontal position. This position is recognisable by the fact that the largest upward and downward movements are possible.
- When the holding lugs are in horizontal position, push the direction indicator to the right and tilt it out of the orifice on the left side at the same time.
- Pull lamp holder out of the housing.
- Change the faulty bulb.
- Insert the lamp holder into the housing again. When doing this, make sure that the rubber grommet is in correct position.
- Let the direction indicator snap into the orifice again.

13.3.2 Rear lights



- 1 Brake light/rear light
- 2 Direction indicator/reflectors
- 3 Fog tail light
- 4 Reverse light
- 5 Licence plate light

Fig. 121 Rear lights

All the bulbs of the rear lights are changed as described below.

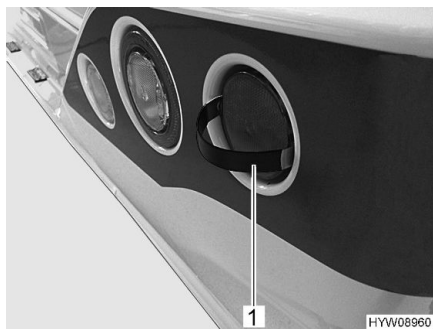


Fig. 122 Remove the cover

- Insert the snap-in lugs of the supplied tool (Fig. 122,1) at the sides of the cover as shown.
- Remove the cover with the tool.
- Change the bulb.
- Applying light pressure, push the cover on the lamp until it snaps into place.

13.4 Replacing bulbs, internal



- ▶ Bulbs and light fittings can be extremely hot. Therefore, allow lights to cool down before changing bulbs.
- ▶ Shut off the power supply on the safety cut-out in the 240 V fuse box before changing bulbs.
- ▶ Store bulbs in a safe place inaccessible to children.
- ▶ Do not use any bulb that has been dropped or which shows scratches in its glass. The bulb might burst.
- ▶ Do not replace the LEDs in lights with standard light bulbs. Risk of fire due to intense heat build up.



- ▷ A new bulb should not be touched with the fingers. Use a cloth when installing the new bulb.
- ▷ Only use bulbs of the same type and with the correct wattage.
- ▷ If LEDs in lights are defect, contact an authorised dealer or service centre.
- ▷ The lights shown in this section are examples. Depending on the model, the lights may differ from the the type displayed here. The examples are intended to point out the possible procedures for changing bulbs in lights.

13.4.1 LED lamps



Fig. 123 LED ceiling lamp (example)



Fig. 124 Recessed LED light (example)



Fig. 125 LED lamp (example)



Fig. 126 Awning light



- ▶ LED lights have a very long life. It is not normally necessary to replace a light.

Changing bulbs:

- Contact a dealer or service centre.

13.5 Spare parts



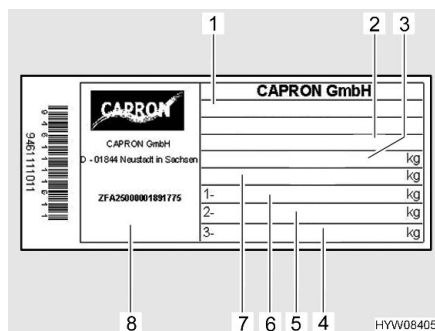
- ▶ Every alteration of the original condition of the vehicle can alter road behaviour and jeopardize road safety.
- ▶ The special equipment and original spare parts recommended by us have been specially developed and supplied for your vehicle. These products are available at your dealer. The dealer is informed about admissible technical details and carries out the required work correctly.
- ▶ The use of accessories, parts and fittings not supplied by us may cause damage to the vehicle and jeopardize road safety. Even if an expert's report, a general type approval or a design certification exists, there is no guarantee for the proper quality of the product.
- ▶ No liability can be assumed for damage caused by products which have not been released by us. This also applies to impermissible alterations to the vehicle.

For safety reasons, spare parts for pieces of equipment must correspond with manufacturer's instructions and be permitted by the manufacturer as a spare part. These spare parts may only be fitted by the manufacturer or an authorised specialist workshop. The authorised dealers and service centres are available for any spare parts requirement.

When ordering spare parts, please indicate the serial number and the vehicle type to the dealer.



13.6 Vehicle identification plate



- 1 Type
- 2 Manufacturer's code and chassis number
- 3 Maximum permissible gross weight of the vehicle
- 4 Free
- 5 Permissible axle load rear
- 6 Permissible axle load front
- 7 Maximum permissible gross weight of the vehicle with trailer
- 8 Serial number

Fig. 127 Vehicle identification plate

The vehicle identification plate (Fig. 127) with the serial number is fitted on the B column on the front passenger side.

Do not remove the vehicle identification plate. The vehicle identification plate:

- Identifies the vehicle
- Helps with the procurement of spare parts
- Together with the vehicle documents identifies the vehicle owner



- ▷ Always include the **serial number** with all inquiries for the customer service office.

13.7 Warning and information stickers

There are warning and information stickers on and inside the vehicle. Warning and information stickers are for the sake of safety and must not be removed.



- ▷ Replacement stickers can be obtained from an authorised dealer or a service centre.



Chapter overview

This chapter contains instructions about the tyres of the motorhome.

The instructions address the following topics:

- tyre selection
- handling of tyres

At the end of the chapter there is a table you can use to find the correct tyre pressure for your vehicle.

14.1 General



- ▶ Check tyre pressure before a journey or every 2 weeks. Wrong tyre pressure causes excessive wear and can lead to damage or even to tyre burst. You can lose control of the vehicle (see section 14.6).



- ▷ Check the tyre pressure on cold tyres. Do not reduce the higher tyre pressure when the tyres are warm.
- ▷ Tubeless tyres have been installed on the vehicle. Never install tubes in these tyres.
- ▷ Read the instruction manual for the base vehicle.



- ▷ Depending on the model, the vehicle may only be equipped with a tyre repair kit as standard.
- ▷ In the case of a puncture, pull the vehicle over to the side of the road. Make vehicle safe with a hazard warning triangle. Switch on the warning lights.
- ▷ Tyres must not be older than 6 years as the material will become brittle over time. The four-digit DOT number on the tyre flank indicates the date of manufacture. The first two digits designate the week, the last two digits the year of manufacture.

Example: (1415) Week 14, year of manufacture 2015.

Observe:

- Check the tyres regularly (every 2 weeks) for equal tread wear, tread depth and external damage.
- Replace tyres at the latest, when the minimum depth of tread stipulated by law is reached.
- Always use tyres of the same model, same brand and same style (summer and winter tyres).
- Only use tyres approved for the wheel rim type fitted. The permitted rim and tyre sizes are quoted in the vehicle documents and the authorised dealer or service centre will always be glad to give you advice.
- Run-in new tyres for approx. 100 km (60 miles) at low speed since only then do they reach full strength.

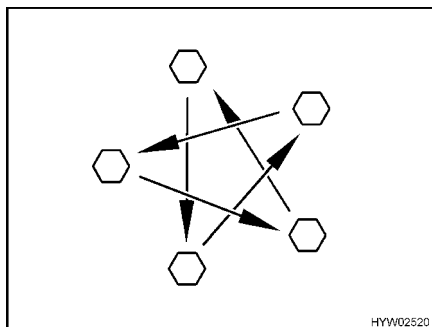


Fig. 128 Tighten the wheel nuts or wheel bolts cross-wise

- Check regularly that the wheel nuts or wheel bolts are firmly seated. Re-tighten the wheel nuts or wheel bolts of a changed wheel after 50 km (30 miles) (Fig. 128).
- When using new or newly painted wheel rims, re-tighten the wheel nuts or wheel bolts once again after approx. 1,000 to 5,000 km (600 miles to 3,000 miles) (Fig. 128).
- For lay-ups or long periods of inactivity, keep the tyres and tyre bearings free from pressure points:
Jack up the vehicle so that the wheels do not bear any load, or move the vehicle every 4 weeks in such a way that the position of the wheels is changed.

14.2 Tyre selection



- ▶ A wrong tyre can damage the tyres during the journey and even cause it to burst.



- ▷ If tyres that are not approved for the vehicle are used, then the type approval for the vehicle and subsequently the insurance coverage can lapse. Your dealer or service centre will be glad to advise you.

The tyre sizes approved for the vehicle are given in the vehicle documents or can be got from the dealers or service centres. Each tyre must fit the vehicle on which it will be driven. This applies to the external dimensions (diameter, width), which are indicated with the standardised size designations. In addition, the tyres must meet the requirements of the vehicle with regard to weight and speed.

Weight refers to the maximum permissible axle load which can be distributed on two tyres. The maximum load-carrying capacity of a tyre is indicated by its load index (= LI, load index code).

The axle geometry of a vehicle, such as wheel camber and track, is also important for tyre selection. The maximum permissible speed for a tyre (with full load-carrying capacity) is indicated by the speed index (= SI). Together, load index and speed index form the operating code of a tyre. This is an official component of the complete, standardised dimensions description which appears on every tyre. The information on the tyres must correspond to the specifications which appear in the vehicle papers.



14.3 Tyre specifications

215/70 R 15C 109/107 Q
(example)

Description	Explanation
215	Tyre width in mm
70	Height-to-width proportion in percent
R	Tyre design (R = radial)
15	Rim diameter in inches
C	Commercial (transporter)
109	Load index code for single tyres
107	Load index code for twin tyres
Q	Speed index (Q = 160 km/h)

14.4 Handling of tyres

- Drive over kerbs at an obtuse angle. Otherwise the flanks of the tyres may get pinched. Driving over a kerb at a sharp angle can damage the tyre and result in it getting ruptured.
- Drive over high manhole covers at a slow speed. Otherwise the tyres may get pinched. Driving over a high manhole cover at high speed can damage the tyre and result in it getting ruptured.
- Check the shock absorbers regularly. Driving with poor shock absorbers significantly increases wear.
- If the tread wear is uneven, have the toe-in and the wheel camber checked. Driving with an incorrectly set toe-in or a one-sided wheel camber leads to a significant increase in wear.
- Do not clean the tyres with a high-pressure cleaner. The tyres can suffer serious damage within just a few seconds and rupture as a result.
- Drive in such a way as to protect your tyres. Avoid braking sharply, revving up too strongly and long journeys on poor roads.

14.5 Tightening torque

Fiat base vehicle

Wheel rim	Tightening torque
Steel wheel rim 15"	160 Nm
Steel wheel rim 16"	180 Nm
Alloy wheel rim 15"	140 Nm
Alloy wheel rim 16"	160 Nm

14.6 Tyre pressure



- ▶ Tyres overheat if the tyre pressure is too low. This can cause serious tyre damage.
- ▶ Check tyre pressure before a journey or every 2 weeks. Wrong tyre pressure causes excessive wear and can lead to damage or even to tyre burst. You can lose control of the vehicle.
- ▶ Use only valves that are approved for the specified tyre pressure.



- ▷ Check the tyre pressure on cold tyres. Do not reduce the higher tyre pressure when the tyres are warm.

The payload and the durability of tyres is directly dependent on the tyre pressure. Air is a volatile medium. It is unavoidable that it will escape from tyres.

As a rule of thumb it can be assumed that a filled tyre loses pressure at a rate of 0.1 bar every two months. To prevent the tyres becoming damaged or burst, check the tyre pressure regularly.

The contact surface of the tyre changes, depending on the tyre pressure.

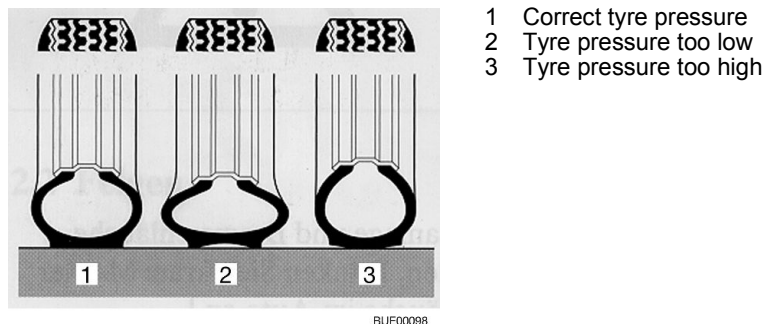


Fig. 129 Contact surface of the tyre



- ▷ The information on pressure levels is valid for cold tyres and loaded vehicles.
- ▷ Pressure in hot tyres is higher than in cold tyres. Therefore, check the pressure when the tyres are cold.
- ▷ Tyre pressures in bar.
- ▷ Over 4.75 bar requires a metal valve.
- ▷ When a replacement is needed, we recommend "Camping" tyres.

The vehicles are constantly brought up to the newest technical standards. It is possible that new tyre sizes are not yet included in this table. If this is the case, any dealer will be happy to provide the newest values.

Fiat

Types	Tyre size	Front air pressure in bar	Rear air pressure in bar
All types	215/70 R 15 C/CP (109/107) Q	4.25	4.5
All types with "Camping" tyres	215/70 R 15 C/CP (109/107) Q	4.75	5.5
All types	225/75 R 16 C/CP (116/114) R	4.5	5.0
All types with "Camping" tyres	225/75 R 16 C/CP (116/114) R	4.75	5.5



15.1 Chapter overview

This chapter contains instructions about possible faults in your vehicle. The faults are listed with their possible causes and corresponding remedies. The instructions address the following topics:

- braking system
- electrical system
- gas system
- gas cooker
- gas oven
- extractor hood
- heater (with boiler function)
- refrigerator
- water supply
- body

The specified faults can be remedied with relative ease and without a great deal of specialised knowledge. In the event that the remedies detailed in this instruction manual should not be successful, an authorised specialist workshop must find and eliminate the cause of the fault.

15.2 Braking system



- ▶ Have defects on the braking system immediately remedied by an authorised specialist workshop.

15.3 Electrical system



- ▷ When the living area battery is changed, only use batteries of the same type and the same capacity.




- ▷ See chapter 9 for changing the fuses.

Fault	Cause	Remedy
Road light system does no longer work correctly	Bulb is defective	Replace bulb. Note volts and watts specifications
Interior lighting does not work	Fuse on the transformer/rectifier is defective	Replace fuse on the transformer/rectifier
	Illuminant, plug connector or cable faulty	Contact customer service
The electrically operated entrance step cannot be moved in or out	Fuse on the transformer/rectifier is defective	Replace fuse on the transformer/rectifier
No 240 V power supply despite connection	240 V automatic circuit breaker has triggered	Switch on the 240 V automatic circuit breaker



Fault	Cause	Remedy
Starter or living area battery is not charged when operated in 240 V mode	Jumbo flat fuse (40 A) on the starter or living area battery is defective	Replace jumbo flat fuse (40 A) on the starter or living area battery
	Charger module in the transformer/rectifier is defective	Contact customer service
Living area battery is not charged during vehicle operation	Fuse on terminal D+ of the alternator is defective	Replace fuse
	Disconnecter relay in the transformer/rectifier is defective	Contact customer service
12 V indicator lamp does not light up	12 V power supply is switched off	Switch 12 V power supply on
	Battery cut-off switch on the transformer/rectifier is switched off	Set battery cut-off switch to on
	Starter or living area battery is not charged	Charge the starter or living area battery
	Disconnecter relay in the transformer/rectifier is defective	Contact customer service
	Flat fuse (2 A) in the living area battery is defective	Replace flat fuse (2 A) in the living area battery
12 V power supply does not work	12 V power supply is switched off	Switch 12 V power supply on
	Battery cut-off switch on the transformer/rectifier is switched off	Set battery cut-off switch to on
	Living area battery is discharged	Charge the living area battery
	Jumbo flat fuse (40 A) on the living area battery is defective	Replace jumbo flat fuse (40 A) on the living area battery
	Disconnecter relay in the transformer/rectifier is defective	Contact customer service
12 V power supply does not work in 240 V operation	12 V power supply is switched off	Switch 12 V power supply on
	Battery cut-off switch on the transformer/rectifier is switched off	Set battery cut-off switch to on
	Charger module in the transformer/rectifier is defective	Contact customer service
	240 V automatic circuit breaker has triggered	Contact customer service
	Jumbo flat fuse (40 A) on the living area battery is defective	Replace jumbo flat fuse (40 A) on the living area battery



Fault	Cause	Remedy
Starter battery is discharged in 12 V operation	Disconnecter relay in the transformer/rectifier is defective	Contact customer service
	Battery cut-off switch on the transformer/rectifier is switched off	Set battery cut-off switch to on
No voltage is supplied by the living area battery	Living area battery is discharged	Charge living area battery immediately  ▷ Total discharge damages the battery. If the vehicle is to be laid up for a long period, fully charge the living area battery beforehand

15.4 Gas system



- ▶ In case of a defect of the gas system (gas odour, high gas consumption) there is danger of explosion! Close regulator tap on the gas bottle immediately. Open doors and windows and ventilate well.
- ▶ If the gas system is defective: Do not smoke; do not ignite any open flames, and do not operate electric switches (light switches etc.). Check the tightness of gas-conducting parts and lines with leakage search spray. Do not check with an open flame.
- ▶ Have the defective gas system repaired by an authorised specialist workshop.

Fault	Cause	Remedy
No gas	Gas bottle is empty	Change gas bottle
	Gas isolator tap closed	Open the gas isolator tap
	Regulator tap on the gas bottle is closed	Open regulator tap on the gas bottle
	External temperature is too low (-42 °C for propane gas, 0 °C for butane gas)	Wait for higher external temperatures
	Built-in appliance is defective	Contact customer service



15.5 Cooker

Fault	Cause	Remedy
Ignition fuse does not operate (flame does not burn after the control knobs are released)	Heat-up time is too short	Keep control knob pressed for approx. 15 to 20 seconds after ignition
	Ignition fuse is defective	Contact customer service
Flame extinguishes when being reduced to its minimum setting	Thermocouple sensor is incorrectly set	Correctly reset thermocouple sensor (do not bend). The sensor tip should protrude by 5 mm beyond the burner. The sensor neck should not be more than 3 mm away from the burner ring; if necessary, contact customer service

15.6 Extractor hood

Fault	Cause	Remedy
Extractor hood does not work	Power supply is defective	Check fuse, replace if necessary
Extractor hood is not working with full power	Grease filter clogged	Clean the grease filter
	Active carbon filter consumed	Change the active carbon filter

If the faults cannot be rectified using the table or the instruction manual, please contact the customer service.

15.7 Heater/boiler

Fault	Cause	Remedy
Heater does not ignite	Temperature sensor on operating unit or remote sensor defective	Pull out plug on operating unit. The heater then works without thermostat. Contact the customer service as soon as possible
Boiler empties, safety/drainage valve has opened	Internal temperature below 3 °C	Heat inside
Safety/drainage valve cannot be closed	Temperature at safety/drainage valve below 8 °C	Heat inside
Fan wheel runs noisily or not steadily	Fan wheel is soiled	Contact Truma service department
None of the LEDs comes on, device is switched on, operating voltage is connected	Automatic restart is blocked, e.g. following an interruption of the power supply	Reset the device (switch off, wait 5 seconds, switch on again)



Fault	Cause	Remedy
After switching on (winter and summer operation) none of the LEDs comes on	No operating voltage	Check 12 V battery voltage, load battery if necessary
		Check all electrical plug connectors
	Appliance fuse or vehicle fuse defective	Check appliance fuse or vehicle fuse and replace if necessary
After switching on, the green LED comes on but the heater does not work	The temperature set on the control unit is below room temperature	Set a higher temperature on the control unit
Green LED comes on, red LED flashes	The safety switch on the window above the waste gas vent has triggered	Close the window
	Risk of undervoltage; battery voltage too low < 10.4 V	Charge the battery
The heater permanently toggles between minimum and maximum power	Air circulation suction system blocked	Remove blocking of air circulation suction system
Red LED comes on, approximately 30 seconds after the heater is switched on	Regulator tap or gas isolator tap is closed	Open regulator tap or gas isolator tap
	Gas bottle is empty	Change gas bottle
	Combustion air inlet or exhaust gas outlet closed	Uncover openings
After extended operation, heater registers a fault	Gas pressure regulator iced up	Use regulator heater (defroster)
	Level of butane in the gas bottle too high	Use propane gas (especially for temperatures below 10 °C, butane is not suitable for heating)
	Warm air louvres blocked	Remove blocking
Green LED is flashing after switching the heater off	Overrun is active to reduce temperature of appliance	No error; overrun switches off after approximately 5 minutes
After the appliance is switched on, the green and red LEDs come on	Electronics defective	Contact customer service

If these measures do not lead to the elimination of the fault, contact the nearest customer service workshop of the relevant appliance manufacturer. The list of addresses is enclosed with the accompanying appliance documentation. Only authorised qualified personnel may repair the appliance.



15.8 Refrigerator

In the event of a defect contact the nearest customer service workshop of the relevant appliance manufacturer. The list of addresses is enclosed with the accompanying appliance documentation. Only authorised qualified personnel may repair the appliance.

For certain faults, indicators also flash on the operating panel.

Fault	Cause	Remedy
240 V operation faulty	No 240 V power supply	Connect 240 V power supply
	240 V automatic circuit breaker has triggered	Switch on the 240 V automatic circuit breaker
	240 V operating voltage too low	Have the 240 V power supply checked by an authorised specialist workshop
12 V operation faulty	12 V operation is only possible when engine is running	Start the engine or select a different operating mode
	Fuse on the transformer/rectifier is defective	Replace fuse on the transformer/rectifier
	Disconnecter relay in the transformer/rectifier is defective	Contact customer service
	12 V operating voltage too low	Have the 12 V power supply checked by an authorised specialist workshop
Gas operation faulty	Lack of gas	Open regulator tap and gas isolator tap
		Connect a full gas bottle
	Air in the gas pipe	Start refrigerator between 2 and 3 times
	Cobwebs or burnt residue in the burning chamber	Remove the ventilation grill on the outside of the vehicle and clean the burning chamber
Refrigerator does not refrigerate sufficiently	Insufficient ventilation of unit	Check if ventilation grills are covered; remove covers if necessary
		Remove ventilation grills and clean the space behind them (of leaves etc.)
	Ambient temperatures are too high	Remove the ventilation grills periodically
	Refrigerator is at too much of an angle	Position the vehicle horizontally
	Too much ice on the cooling fins	Defrost the refrigerator




15.9 Water supply

Fault	Cause	Remedy
Leakage water inside the vehicle	A leak has occurred	Identify leak, re-connect water pipes
No water	Water tank is empty	Replenish drinking water
	Drain cock not closed	Close drain cock
	12 V power supply is switched off	Switch 12 V power supply on
	Fuse of the water pump is defective	Replace fuse on the transformer/rectifier
	Water pump defective	Exchange water pump (have it exchanged)
	Water pipe snapped off	Straighten water pipe or replace
	Transformer/rectifier defective	Contact customer service
	Water pump switched off on panel	Switch water pump on
Toilet has no flush water	Water tank is empty	Replenish drinking water
	Fuse for toilet is defective	Replace fuse
Display for water and waste water indicates a wrong value	Measuring probe in the waste water or water tank is soiled	Clean water/waste water tank
	Measuring probe is defective	Replace measuring probe
Waste water tank cannot be emptied	Drain cock is clogged	Open the cleaning cap on the waste water tank and drain the waste water. Rinse the waste water tank well
Drain on the single lever mixer tap is clogged	Perlator calcified	De-calcify or replace perlator
Water jets on the shower nozzle clogged	Water jets calcified	De-calcify shower nozzle or rub off nozzle burling
Water drains from the shower tray slowly or does not drain at all	The vehicle is not in a horizontal position	Position the vehicle horizontally
Milkiness of the water	Tank filled with dirty water	Clean water tank mechanically and chemically; then disinfect and rinse copiously with drinking water
	Residues in the water tank or water system	Clean water system mechanically and chemically; then disinfect and rinse copiously with drinking water



Fault	Cause	Remedy
Any change in the taste or odour of the water	Tank filled with dirty water	Clean water system mechanically and chemically; then disinfect and rinse copiously with drinking water
	Fuel filled into the water tank by mistake	Clean water system mechanically and chemically; then disinfect and rinse copiously with drinking water. If not successful: Contact a specialist workshop
	Microbiological deposits in the water system	Clean water system mechanically and chemically; then disinfect and rinse copiously with drinking water
Deposits in the water tank and/or water-carrying components	Water excessively long in the water tank and in water-carrying components	Clean water system mechanically and chemically; then disinfect and rinse copiously with drinking water

15.10 Body

Fault	Cause	Remedy
Flap hinges/door hinges are difficult to operate	Flap/door hinges are not sufficiently lubricated	Lubricate flap hinges/door hinges with acid-free and resin-free grease
Hinges/joints in the bathroom unit/toilet compartment are difficult to operate/make a grating noise	Hinges/joints are not sufficiently lubricated	Lubricate hinges/joints with solvent-free and acid-free grease  ▷ Spray cans often contain solvents
Storage compartment hinges are difficult to operate/make a grating noise	Storage compartment hinges are not sufficiently lubricated	Lubricate storage compartment hinges with acid-free and resin-free grease



▷ The authorised dealers and service centres are available for any spare parts requirement.



Chapter overview

This chapter contains helpful tips for the journey.

The instructions address the following topics:

- traffic rules in foreign countries
- road assistance in European countries
- gas supply in European countries
- toll regulations in European countries
- safe ways to spend the night during travel
- camping in winter

At the end of the chapter there is a checklist containing the most important equipment for the journey.

16.1 Traffic rules in foreign countries



- ▷ The vehicle driver is required to inform himself as to the traffic rules of the countries in which he plans to travel before beginning the trip. Contact your automobile club or embassy for further information.
- ▷ In some European countries, warning vests must be worn when exiting the vehicle outside of towns in the case of vehicle failures or accidents.
- ▷ Depending on the country, different rules and regulations apply (e.g. different warning signs for rear carriers, obligation to carry breathalyzer kits, spare bulbs, high-visibility vests, size of reserve canister). The driver of the vehicle must familiarise him or herself with these rules before every journey.
- ▷ Up-to-date information can generally be found on the web pages of the national automobile associations.

Information about traffic regulations is especially important as state law applies in case of damage. For your own safety, always observe the following rules when travelling abroad:

- Carry your insurance certificate with you.
- Always register accidents with the police.
- Never sign documents that you have not read and understood completely.

16.2 Help on Europe's roads



- ▷ Before commencing the trip, gather information on national phone numbers for rescue and police. In many countries the central emergency phone number 112 (without area code) applies.
- ▷ As far as possible, draw up a list with the important phone numbers in the travelled countries and keep the table in the vehicle.

Motoring clubs at home or in the travelled country are happy to help.



16.3 Gas supply in European countries



- ▷ In Europe, there are several different connection systems for gas bottles. It is not always possible to fill or exchange your gas bottles in a foreign country. Get information about the connection system in the country you are travelling to before embarking on your journey, e.g. at a motoring club or in the trade press.

General tips

Always observe the following instructions:

- Only go on vacation with completely filled gas bottles.
- Use all of the gas bottles' capacity.
- Take along adapter sets (available in camping supply stores) for filling gas bottles in foreign countries and for connecting the gas pressure regulator to foreign gas bottles.
- During the cold time of the year observe filling with propane gas component (butane does not gas below 0 °C).
- Use blue bottles from the firm Campingaz (distributed world-wide). Only use gas bottles with safety valves.
- When bottles from other countries are used, check the gas bottle compartments to see if the gas bottles fit into them. Gas bottles from other countries do not always display the same size as your own gas bottles.
- The web site www.mylpg.eu provides an overview of gas suppliers in Europe.

16.4 Toll regulations in European countries

Many European countries have introduced a mandatory toll system. The toll regulations and how they are collected vary greatly from country to country. Nevertheless, ignorance is no excuse. Penalties can be quite severe.

As is the case with traffic regulations, the vehicle driver is required to be familiar with the toll formalities before starting out on a trip. For example, in Austria the vignette does not meet the toll requirements for vehicles that weigh more than 3.5 t. There, a so-called "Go-Box" must be obtained and charged.

Contact your automobile club or the Internet for further information.



- ▷ Windscreens with solar filters can affect the functioning of automatic toll collection systems (e.g. Go-Box). This must be taken into account when acquiring the appropriate device (e.g. Split-Go-Box).



16.5 Tips on staying overnight safely during travel

Prudent behaviour is the most important protective measure for insuring a safe night in the motorhome.

The risk of thievery is reduced to a minimum when the following basic rules are observed:

- During high season do not spend the night at highway rest stops or parking areas located along typical vacation routes.
- Several vehicles on one site at the same time do not necessarily decrease the chances of thievery occurring. Consult your own feelings about the parking site.
- Even if it is just for one night, go to a camping site.
- When parking on open space keep emergency routes clear. The way to the driver's seat should be clear. The ignition key should always be within reach.
- Only take with you those valuables which are absolutely necessary for the journey. If possible, store valuables in a small safe and not in the immediate vicinity of windows or doors.
- Always lock up the vehicle.

16.6 Tips for winter campers

The following tips will help make your winter camping experience as agreeable as possible.

- Reserve your parking place in good time. Good winter camping sites are often booked up early.
- Do not start your trip without winter tyres.
- Bring snow chains.
- Choose your parking place with care. Observe the ground beneath you. Snow and ice may melt.
- When the vehicle has been positioned, release the handbrake to prevent freezing.
- No snow walls should be allowed to cover the built-in forced ventilation.
- Keep the built-in forced ventilation free from snow and ice.
- Make sure the air circulation is good. Good air circulation prevents moisture from collecting and makes it easier to heat the living area.
- Cover the single-paned driver's cabin window with insulation mats to avoid thermal bridges.
- Follow the instructions in the section "Gas supply in European countries".
- Use a two-bottle system with automatic controller for the gas system, so that the supply does not run out during the night.
- Only operate the gas system using propane gas.
- Do not use the space behind the heater as a storage space.
- Never operate catalytic ovens or infra-red gas radiators in the interior of the vehicle, since they consume oxygen for burning.
- Lay the 240 V power cable in such a way that the cable cannot be frozen or be damaged (e.g. during snow removal).
- When it is snowing heavily, clear the roof of the vehicle of snow regularly. A few centimetres of powdery snow serves as insulation, but wet snow quickly becomes a heavy burden.
- Before embarking on the return journey, remove all the snow from the roof to avoid impeding vehicles behind you with a "snow flag".



16.7 Travel checklists

The following checklists will help that nothing important is left at home although not everything on the checklists might be necessary.



- ▷ Do not leave checking of documents (e.g. vehicle papers and information) as well as checking the condition of the vehicle until just before commencing the trip. Planning and checking documents well in advance will save unnecessary trouble.

Kitchen area

✓	Object	✓	Object	✓	Object
	Wiping cloth		Cleansing agent (detergent)		Salad servers
	Silverware		Dishcloths		Chopping board
	Turnspit		Glasses		Brush to wash the dishes
	Can opener		Set of knives and forks for grilling		Cloth to wash the dishes
	Ice cube tray		Corkscrew		Matches
	Lighter		Kitchen paper		Thermos jug
	Bottle opener		Garbage bags		Pots
	Air-tight storage boxes		Frying pans		
	Crockery		Stirring spoons		

Bathroom/sanitary items

	Towels		Sanitary items		Toilet paper
	Hygiene products		Toilet brush		Toothbrush glass

Living area

	Dustbin		Deck of cards		Rucksack
	Road atlas		Broom		Sleeping bags
	Bath towels		Dust pan		Pencils and paper
	Bath shoes		Candles		Shoes
	Batteries		Coat-hangers		Shoe polish
	Bed linen		Clothes brush		Sports equipment
	Laundry bag		Pillow		Vacuum cleaner
	Books		Map		Flash light
	Camping guide/ parking space directory		Medicine		Pocket knife
	Binoculars		Mobile phone		Table cloth
	Fire extinguisher		Sewing kit		Drinking bottle
	Gas bottle		Rain clothes		Clothes pins
	Insect lamp		First aid kit		Clothesline
	Insect repellent		Travel guide		



Vehicle/tools

✓	Object	✓	Object	✓	Object
	Waste water container		Gas tube		Snow chains (winter)
	Adapter socket		Fabric tape		Screwdriver
	CEE adapter		Watering can for drinking water		Current-measuring instrument
	Wire		Cable reel		Wheel chocks
	Spare wheel		Glue		First-aid kit
	Spare lamps		Universal pliers		Vehicle jack
	Spare fuses		Compressor		Hazard warning triangle
	Hammer		Loops		Warning sign
	Flat wrench		Tube adapter		Warning vest(s)
	Gas filling adapter		Hose clips		Flashing hazard warning light

Outside

	Stay rope		Camping table		Lock
	Bellows		Luggage racks		String
	Camping chairs		Grill		Tent pegs/ tightening ropes

Documents

	List of addresses		Registration book		Passport
	Registration confirmation(s)		Driving licence		Writ of protection
	Allergy certificate		Vaccination certificate		Insurance documents
	Instruction manuals		Credit card		Vignette/toll card
	Instruction leaflets for medicines		Identity card		Visa





12 V fuses	86	Brakes	34
For the Thetford toilet	87	Check	34, 139
Next to transformer/rectifier	87	Braking system, troubleshooting	139
On the living area battery	87	Branch block	27
On the starter battery	86	Breakdown services in Europe	147
12 V main switch	81	Bulbs, changing	129, 132
12 V power supply	74	Direction indicator, on the side	130
Switching on	81	Exterior lighting	129
Troubleshooting	140	Front lights	130
240 V connection	40, 84	Rear lights	131
Troubleshooting	139	Bunk bed	61
240 V fuse	88	Access ladder	62
Position	88	Conversion	62
240 V fuse box	88	Safety net	62
240 V power supply	84	Butane gas	15, 68
A			
Access ladder, bunk bed	62	C	
Access ladder, overcab bed	59	Cable reel	84
Access ladder, pull-down bed	61	Camping gas bottles, use	16, 69
Accessories, fitting	12	Camping in winter	149
Actual weight	18, 21	Capacity of the battery	74
Additional equipment	20	Care	119
Add-on parts see special equipment	12	Blind	122
Air outlet nozzles, adjustment	91	Carpet	121
Appliances	89	Curtains	121
Manuals	12	Entrance step	121
B			
Basic equipment	19	External care	119
Battery cut-off switch	79	Extractor hood	124
Battery monitor	80	Furniture surfaces	121
Battery see starter battery		Gas cooker	121
and living area battery	75	High-pressure cleaner, washing with	119
Battery selector switch	79	In the winter	125
Beds	59	Insect screen	122
Before the journey	17	Interior care	121
Bike rack		Lamps	121
Load	24	Net curtains	121
Travelling with a loaded bike rack	24	PVC-floor covering	121
Blind, cleaning	122	Roman shade	122
Blind, window		Seat belt	122
Closing	48	Sink	121
Opening	48	Synthetic parts, interior	121
Boiler	93	Temporary lay-up	126
Bonnet	28	Underbody	120
Closing	28	Upholstery	121
Opening	28	Washing	120
C			
Cable reel 84			
Camping gas bottles, use 16, 69			
Camping in winter 149			
Capacity of the battery 74			
Care 119			
Blind 122			
Carpet 121			
Curtains 121			
Entrance step 121			
External care 119			
Extractor hood 124			
Furniture surfaces 121			
Gas cooker 121			
High-pressure cleaner, washing with 119			
In the winter 125			
Insect screen 122			
Interior care 121			
Lamps 121			
Net curtains 121			
PVC-floor covering 121			
Roman shade 122			
Seat belt 122			
Sink 121			
Synthetic parts, interior 121			
Temporary lay-up 126			
Underbody 120			
Upholstery 121			
Washing 120			
Waste water tank 123			
Water pipes 122			



Water system 122
 Water tank 122
 Windows 120
 Winter lay-up 127
 Carpet, cleaning 121
 Changing wheels, tightening torque 137
 Checklist 30
 Before the journey 30
 For the journey 150
 Initial start-up after temporary lay-up 128
 Road safety 30
 Temporary lay-up 126
 Winter lay-up 127
 Checks see checklist 126
 Children's beds 59, 60, 61
 Circulation fan 90, 93
 Cleaning see care 119
 Cleaning, water tank 122
 Closed circuit current 73
 Condensation 44, 45
 Condensation on the double
 acrylic glass pane 45
 Condensation on the screwed
 connections in the floor 44
 Connecting cable see
 240 V power supply 84
 Conventional load 20
 Conversion door 41
 Insect screen 43
 Conversion door, inside
 Locking 42
 Opening 42
 Conversion door, outside
 Locking 41
 Opening 41
 Cooker 100
 Troubleshooting 142
 Curtains, cleaning 121

D

Danger of suffocation 12, 44
 Direction indicator 130
 Disposal
 Household waste 8
 Sewage 8
 Waste water 8
 Door lock 41

Doors
 Conversion door 41, 42
 Driver's door 41, 42
 Lock 41
 Troubleshooting 146
 Drinking water filler neck 108
 Closing 108
 Opening 108
 Driver's door 41
 Driver's seat 36
 Driving speed 34
 Driving the motorhome 33
 During the journey 33

E

Electrical system 73
 240 V connection, troubleshooting 139
 Entrance step, troubleshooting 139
 Explanation of terms 73
 Lighting, troubleshooting 139
 Safety instructions 16
 Troubleshooting 139
 Electrical window winder
 Closing 37
 Opening 37
 Electrically adjustable external mirrors 38
 Engine oil level, checking 29
 Entrance step 25, 39
 Care 121
 Extending 25
 Retracting 25
 Troubleshooting 139
 Warning tone 25
 Environmental tips 8
 Exterior lighting
 Bulbs, changing 129
 Checking 30
 Troubleshooting 139
 External care 119
 External connection see
 240 V connection 40
 External flaps 43
 Flap lock 43, 44
 External mirrors, electrically adjustable
 Adjusting 38
 Mirror heater, switching on 38
 Extractor hood 103
 Care 124
 Troubleshooting 142



F	
Fault current protection switch	84
Check	88
Filling the tank	38
Fire	
Behaviour in the event of	11
Extinguishing	11
Fire prevention	11
Fire risks, avoidance	11
FI-switch see fault current protection switch	88
Fixed bed	62
Closing	63
Opening	63
Flap lock	
Closing	44
Elliptical-shaped	44
Opening	44
Flat screen	
Driving position	58
Television position	57, 58
Floor warming unit, electrical	
Overload protection	99
Switching off	99
Switching on	99
Forced ventilation	12, 44
Front bench seat, sleeping conversion	64, 65, 66
Front passenger's seat	36
Fuel filler neck	38
Furniture flaps, troubleshooting	146
Furniture surfaces, cleaning	121
Fuse box	88
Fuses	
12 V fuses	86
240 V fuse	84, 88
For the Thetford toilet	87
Next to transformer/rectifier	87
On the living area battery	87
On the starter battery	86
Fuses see 12 V fuses and 240 V fuse	86
G	
Gas bottle compartment	15, 68
Gas bottles	
Changing	70
Safety instructions	15, 69
Gas consumption	70
Gas cooker	
Cleaning	121
Switching off	101
Switching on	101
Troubleshooting	142
Gas isolator taps	71
Closing	71
Opening	71
Symbols	71, 89
Gas odour	14, 67, 141
Gas oven	101
Switching off	102
Switching on	102
Gas pressure regulator, screw connections	69
Gas supply in European countries	148
Gas system	67
Defect	14, 67, 141
General instructions	14
Safety instructions	14, 67
Troubleshooting	141
General instructions	8
Grill	101
Switching off	102
Switching on	102
H	
Handbrake	39
Applying	12
Handling of tyres	137
Headlights	130
Headrests	36
Heat exchanger, heater, replacement	89
Heater	90
Air outlet nozzles, adjustment	91
Branch block	27
Circulation fan	90, 93
Heat exchanger, replacement	89
Hot air distribution	91
Initial start-up	90
Operating modes	92
Troubleshooting	142
Heater safety/drainage valve	97
Heater, external mirrors	38
Heki skylight	53
Closing	53
Insect screen	54



Opening	53	Lay-up	
Roman shade	54	Temporary	126
Ventilation position	54	Temporary (toilet)	118
Help on Europe's roads	147	Winter lay-up	127
Helpful notes	147	Leakage water inside the vehicle	145
High rate of gas consumption	14, 67, 141	LED lamp	132
High-pressure cleaner, washing with	119	Switching on/off	57
Hinged window		Lift-off table	56
Blind	48	Conversion to bed foundation	56
Closing	46	Moving forwards/backwards	56
Continuous ventilation	46	Lighting	
Insect screen	48	Front	130
Opening	46	Lamps, cleaning	121
Hot air distribution	91	LED lamp	57
Hot-air heater	93	Rear	131
Circulation fan	90, 93	Troubleshooting	139
Operating unit	93	Lights see bulbs, changing	132
Troubleshooting	142	Living area battery	
I		Discharging	76
Indicator lamp, toilet	116	Fuses	87
Information stickers	134	Instructions	75
Initial start-up	17	Position	75
Inner door, troubleshooting	146	Troubleshooting	140, 141
Insect screen, cleaning	122	Load	22
Insect screen, conversion door		Bike rack	24
Closing	43	Rear garage	23
Opening	43	Rear storage space	23
Insect screen, Heki skylight		Load see also payload	22
Closing	54	Lock	
Opening	54	Conversion door	41
Insect screen, windows		Driver's door	41
Closing	48, 50	External flap	43, 44
Opening	48, 50	Low beam	130
Inspection work	129	M	
Inspections	129	Main beam	130
Interior care	121	Maintenance work	129
Interior lighting		Mass in ready-to-drive condition	19
Bulbs, changing	132	Maximum permissible gross weight	18, 21
Troubleshooting	139	Mechanical steady legs	
L		Extending	40
Ladder, bunk bed	62	Length, adjustment	40
Ladder, overcab bed	59	Retracting	40
Ladder, pull-down bed	61	N	
Lamps	57, 132	Net curtains, cleaning	121
Cleaning	121	No gas	141
Operating	57		



O	
Off-load voltage	73
Operating modes, heater	92
Operating modes, production of hot water	92
Operating modes, refrigerator (Thetford)	104
Operating unit, hot-air heater	93
Oven see gas cooker or gas oven	100, 101
Overcab bed	59
Access ladder	59
Safety net	59
Overloading	22
P	
Panel (LT 100)	81
12 V main switch	81
Panel see also displays	81
Parking light	130
Payload	18
Calculation	21
Composition	19
Example calculation	19, 21
Payload see also load	18
Permissible gross weight see maximum permissible gross weight	18
Personal equipment	20
Production of hot water	90
Emptying	97
Operating modes	92
Safety/drainage valve	97
Switching off	92, 93
Switching on	92, 93
Troubleshooting	142
Water, filling in	97
Propane gas	15, 68
Pull-down bed	60
Access ladder	61
Closing	61
Opening	61
Retaining straps, tightening	61
PVC-floor covering	26
PVC-floor covering, cleaning	121
R	
Ramps	39
Rear garage	23
Rear lights	131
Rear storage space	23
Refrigerator	40, 103
Door lock	106
Gas operation, switching off	105
Gas operation, switching on	105
Operating modes	104
Troubleshooting	144
Ventilation grill, removal	104
Refrigerator door locking mechanism	
Closing	106
Locking in the ventilation position	106
Opening	106
Refrigerator ventilation grill, removal	104
Registration	17
Risk of frost damage	16, 107, 111
Road safety	30
Checklist	30
Notes for	12
Roman shade, cleaning	122
Roman shade, Heki skylight	
Closing	54
Opening	54
Roman shade, side pane	
Closing	47
Opening	47
Securing	26
Roman shade, windows	
Closing	50
Opening	50
Roman shade, windscreen	
Closing	47
Opening	47
Securing	26
S	
Safety cut-out	88
Safety instructions	11
Cooker	100
Electrical system	16
Fire prevention	11
Gas bottles	69
Gas system	14, 67
Road safety	12
Towing	14
Water system	16
Safety knob, hinged window	46
Safety net, bunk bed	62
Safety net, overcab bed	59
Safety net, pull-down bed	61



Extractor hood	142	Waste water tank	112
Furniture flaps	146	Care	123
Gas cooker	142	Cleaning	123
Gas system	141	Emptying	113
Heater	142	Troubleshooting	145
Hot-air heater	142	Waste water tap	112
Inner door	146	Water pipes, cleaning	122
Lighting	139	Water pump	107, 108
Living area battery	140	Water supply	
Production of hot water	142	General	107
Refrigerator	144	Troubleshooting	145
Starter battery	140	Water system	
Toilet	145	Care	122
Water supply	145	Cleaning	122
TV unit	57	Disinfecting	123
Tyre specifications	137	Drinking water filler neck	108
Tyres	135	Emptying	111
Excessive wear	13, 30, 135, 137	Filling	108
General instructions	135	Safety instructions	16
Handling	137	Water tank	
Identification	137	Cleaning	122
Tyre pressure	137	Water quantity, reducing	110
Tyre selection	136	Water, draining	110
		Water, filling with	109
		Water tank see also water system	108
		Wheel rim type	135
		Wheels	135
		Window winder	
		Closing	37
		Opening	37
		Windows	45
		Blind	48
		Insect screen	48, 50
		Roman shade	50
		Windows, cleaning	120
		Windscreen washer fluid, filling in	28
		Winter care	125
		Winter operation	125
U			
Underbody, maintenance	120		
Unladen weight	19		
Upholstery, cleaning	121		
V			
Vario toilet compartment	114		
Converting into a shower cubicle	115		
Converting into toilet compartment	115		
Vehicle identification plate	134		
Vehicle lighting see exterior lighting	129		
Vehicle, washing	120		
Ventilation	44		
Toilet compartment	113		
W			
Warning stickers	134		
Warranty	5		
Warranty certificate	5		
Washing with a high-pressure cleaner	119		
Waste gas vent on the right hand side of the vehicle	90		

